

BRUSHLESS AC/DC MOTOR UNIT - Gearhead

DIMENSIONS

GEARHEAD K9H□B

K9H□B
Weight : 1.3Kg

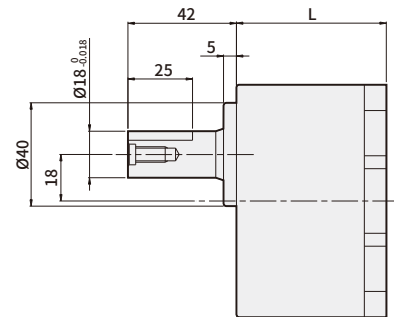
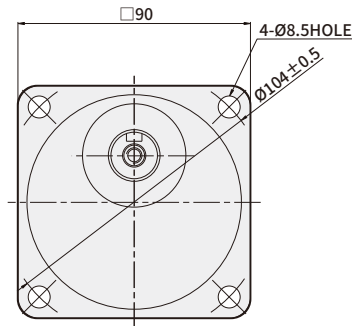

K9BH90N■ + K9H□B
K9BH150NC + K9H□B
K9FH150NC + K9H□B
K9XH100N2 + K9H□B
Weight : 2.6Kg

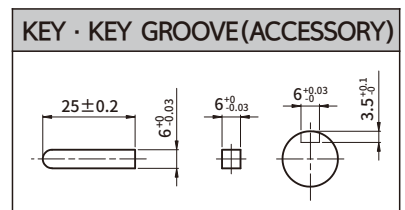
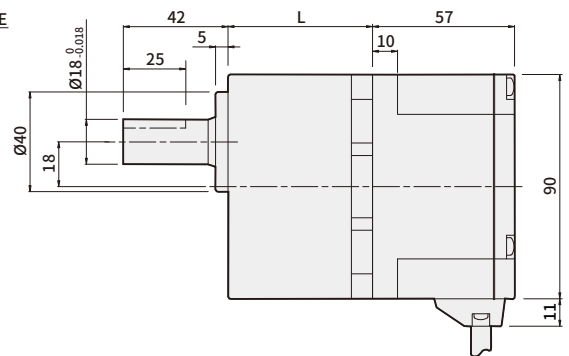
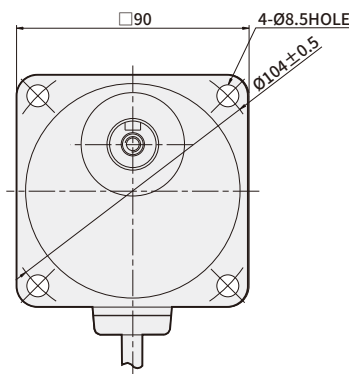

DIMENSION TABLE

GEARHEAD PRODUCT NAME	DECCELERATION RATIO	L	FIXING BOLT
K9H□B	5,10,15,20	45	M8 P1.25×75
	30,50,100	58	M8 P1.25×90
	200	64	M8 P1.25×95

- ※ -B (BRAKE), -E (ENCODER) or -BE (BRAKE+ENCODER) can be added to end of the motor model name.
- ※ In ■ of the model name voltage U (single-phase 100~115V), C (single-phase 200~230V) will be shown.
- ※ In □ of name, it represents a deceleration ratio.
- ※ Geared motor is included with fixing bolt set. (flat washer, spring washer, hexagonal nut 4pcs each)

→ Delivery efficiency of gearhead

Product name	Deceleration ratio	5	10	15	20	30	50	100	200
	K6H□B		90%				86%		
K8H□B		90%				86%			81%
K9H□B		90%				86%			81%
K10H□BU		90%				86%		81%	
K6H□BTH		80%	85%						
K8H□BTH		85%							
K9H□BTH		85%							
K10H□BTH		85%							

→ Allowed torque of AC Motor + Gearhead

Unit = N·m

Product name	Deceleration ratio	5	10	15	20	30	50	100	200
	Speed control range[r/min]	20~600	10~300	6.7~200	5~150	3.3~100	2~60	1~30	0.5~15
K6BH30N■ + K6H□B	100~3000	0.45	0.9	1.4	1.8	2.6	4.3	6	6
K8BH60N■ + K8H□B		0.9	1.8	2.7	3.6	5.2	8.6	16	16
K9BH90N■ + K9H□B		1.35	2.7	4.1	5.4	7.7	12.9	25.8	30
K9BH150NC + K9H□B		2.2	4.4	6.6	8.8	12.6	21.1	30	30
K6BH30N■ + K6H□BTH		0.4	0.85	1.3	1.7	2.6	4.3	8.5	17
K8BH60N■ + K8H□BTH		0.85	1.7	2.6	3.4	5.1	8.5	17	34
K9BH90N■ + K9H□BTH		1.9	3.8	5.7	7.7	11.5	19.1	38.3	68
K9BH150NC + K9H□BTH		2.1	4.2	6.2	8.3	12.5	21	42	68
Product name	Deceleration ratio	5	10	15	20	30	50	100	200
	Speed control range[r/min]	20~800	10~400	6.7~266	5~200	3.3~133	2~80	1~40	0.5~20
K6FH30NC+K6H□B	100~3000	0.45	0.9	1.4	1.8	2.6	4.3	6	6
	4000	0.36	0.72	1.08	1.4	2.1	3.4	5.4	5.4
K8FH60NC+K8H□B	100~3000	0.9	1.8	2.7	3.6	5.2	8.6	16	16
	4000	0.68	1.4	2.0	2.7	3.9	6.5	12.9	14
K9FH150NC+K9H□B	100~3000	2.2	4.4	6.6	8.8	12.6	21.1	30	30
	4000	1.4	2.7	4.1	5.4	7.7	12.9	25.8	27
K10FH200NC+K10H□BU	100~3000	2.9	5.9	8.8	11.7	16.8	28	52.7	70
	4000	2	4.1	6.1	8.1	11.6	19.4	36.5	63
K10FH400NC+K10H□BU	100~3000	5.9	11.7	17.6	23.4	33.5	55.9	70	70
	4000	4.3	8.6	12.8	17.1	24.5	40.9	63	63
K6FH30NC+K6H□BTH	100~3000	0.4	0.85	1.3	1.7	2.6	4.3	8.5	17
	4000	0.30	0.64	0.96	1.3	1.9	3.2	6.4	12.8
K8FH60NC+K8H□BTH	100~3000	0.85	1.7	2.6	3.4	5.1	8.5	17	34
	4000	0.64	1.3	1.9	2.6	3.8	6.4	12.8	25.5
K9FH150NC+K9H□BTH	100~3000	2.1	4.2	6.2	8.3	12.5	21	42	68
	4000	1.3	2.6	3.8	5.1	7.7	12.8	25.5	51
K10FH200NC+K10H□BTH	100~3000	2.8	5.5	8.3	11.1	16.6	27.6	55.3	—
	4000	1.9	3.8	5.7	7.7	11.5	19.1	38.3	—
K10FH400NC+K10H□BTH	100~3000	5.5	11.1	16.6	22.1	33.2	55.3	110	—
	4000	4.0	8.1	12.1	16.2	24.2	40.4	80.8	—

- * -B (BRAKE), -E (ENCODER) or -BE (BRAKE+ENCODER) can be added to end of the motor model name.
- * In ■ of the model name voltage U (single-phase 100~115V), C (single-phase 200~230V) will be shown.
- * In □ of name, it represents a deceleration ratio.
- * Rotation direction shows the same [] color as the motor. In other cases, it's the opposite.
- * Flat Gearbox viewed from front side is opposite rotation direction with motor.
- * Flat Gearbox viewed from back side is same rotation direction with motor.

→ Allowed torque of DC Motor + Gearhead

Unit = N·m

Product name	Deceleration ratio	5	10	15	20	30	50	100	200
	Speed control range[r/min]	20~600	10~300	6.7~200	5~150	3.3~100	2~60	1~30	0.5~15
K6XH30N2 + K6H□B	100~2500	0.54	1.1	1.6	2.2	3.1	5.2	6	6
	3000	0.3	0.54	0.81	1.1	1.5	2.6	5.2	6
K8XH50N2 + K8H□B	100~2500	0.9	1.8	2.7	3.6	5.2	8.6	16	16
	3000	0.45	0.9	1.4	1.8	2.6	4.3	8.6	16
K9XH100N2 + K9H□B	100~2500	1.8	3.6	5.4	7.2	10.3	17.2	30	30
	3000	0.9	1.8	2.7	3.6	5.2	8.6	17.2	30
K6XH30N2 + K6H□BTH	100~2500	0.48	1	1.5	2	3.1	5.1	10.2	17
	3000	0.2	0.51	0.77	1	1.5	2.6	5.1	10.2
K8XH50N2 + K8H□BTH	100~2500	0.85	1.7	2.6	3.4	5.1	8.5	17	34
	3000	0.43	0.85	1.3	1.7	2.6	4.3	8.5	17
K9XH100N2 + K9H□BTH	100~2500	1.7	3.4	5.1	6.8	10.2	17	34	68
	3000	0.85	1.7	2.6	3.4	5.1	8.5	17	34
Product name	Deceleration ratio	5	10	15	20	30	50	100	200
	Speed control range[r/min]	20~800	10~400	6.7~267	5~200	3.3~133	2~80	1~40	0.5~20
K10XH200N2 + K10H□BU	100~3000	2.9	5.9	8.8	11.7	16.8	28	52.7	70
	4000	2.0	4.1	6.1	8.1	11.6	19.4	36.5	63
K10XH400N9 + K10H□BU	100~3000	5.9	11.7	17.6	23.4	33.5	55.9	70	70
	4000	4.3	8.6	12.8	17.1	24.5	40.9	63	63
K10XH200N2 + K10H□BTH	100~3000	2.8	5.5	8.3	11.1	16.6	27.6	55.3	—
	4000	1.9	3.8	5.7	7.7	11.5	19.1	38.3	—
K10XH400N9 + K10H□BTH	100~3000	5.5	11.1	16.6	22.1	33.2	55.3	110	—
	4000	4.0	8.1	12.1	16.2	24.2	40.4	80.8	—

※ -B (BRAKE), -E (ENCODER) or -BE (BRAKE+ENCODER) can be added to end of the motor model name.

※ In □ of name, it represents a deceleration ratio.

※ Rotation direction shows the same color as the motor. In other cases, it's the opposite.

※ Flat Gearbox viewed from front side is opposite rotation direction with motor. Flat Gearbox viewed from back side is same rotation direction with motor.

→ Allowed overhang load and allowed thrust

Product name		Deceleration ratio	Allowed overhang load				Allowed thrust load	
			From the end of output part 10mm		From the end of output part 20mm		N	kgf
			N	kgf	N	kgf		
GEARHEAD	K6H□B	5	100	10	150	15	40	4
		10,15,20	150	15	200	20		
		30,50,100,200	200	20	300	30		
	K8H□B	5	200	20	250	25	100	10
		10,15,20	300	30	350	35		
		30,50,100,200	450	45	550	55		
	K9H□B	5	300	30	400	40	150	15
		10,15,20	400	40	500	50		
		30,50,100,200	500	50	650	65		
	K10H□BU	5,10,15,20	550	55	800	80	200	20
		30,50	1000	100	1250	125	300	30
		100,200	1400	140	1700	170	400	40
	K6H□BTH	5,10	450	45	370	37	200	20
		15~200	500	50	400	40		
	K8H□BTH	5,10	800	80	660	66	400	40
		15~200	1200	120	1000	100		
	K9H□BTH	5,10	900	90	770	77	500	50
		15,20	1300	130	1110	111		
		30,50,100,200	1500	150	1280	128		
	K10H□BTH	5,10	1230	123	1070	107	800	80
		15,20	1680	168	1470	147		
30,50,100		2040	204	1780	178			
MOTOR	K6BS30N■,K6FS30NC K6XS30N2		70	7	100	10	· Do not apply THRUST load Please. If you can't help it, 50% or less.	
	K8BS60N■,K8FS60NC K8XS50N2		120	12	140	14		
	K9BS90N■,K9BS150NC K9FS150NC,K9XS100N2		160	16	170	17		
	K10FS200NC,K10FS400NC K10XS200N2,K10XS400N9		197	19.7	220	22		

- ※ -B (BRAKE), -E (ENCODER) or -BE (BRAKE+ENCODER) can be added to end of the motor model name.
- ※ In ■ of the model name voltage U (single-phase 100~115V), C (single-phase 200~230V) will be shown.
- ※ In □ of name, it represents a deceleration ratio.
- ※ Permissible overhang load can be withdrawn by calculation.