

## BRAKE MOTOR

### 200W

### □90mm

K9□S200F□-B

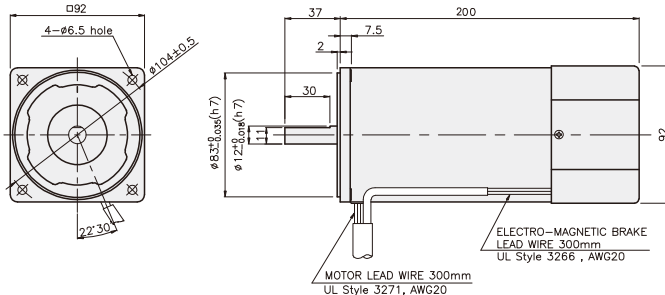

### SPECIFICATIONS

200W continuous rating, four poles

Model	Duty	Voltage (V)	Frequency (Hz)	Current (A)	Start T. (N·m/Kgf·cm)	Rated T. (N·m/Kgf·cm)	Speed (rpm)	Condenser (μF)	Friction T. (N·m/Kgf·cm)
K9I□200FT-B	three-phase	continuous	200	50	1,62	4/40	1,5/15	-	1/10
				60	1,29	3,15/31,5	1,22/12,1		
K9I□200FH-B			220	50	1,36	4,25/42,5	1,45/14,5	-	1/10
				60	1,06	3,4/34	1,22/12,2		
			230	50	1,51	4,3/43	1,45/14,5		
				60	1,15	3,5/35	1,22/12,2		
K9I□200FM-B			380	50	0,81	4,3/43	1,45/45,5	-	1/10
				60	0,58	3,6/36	1,22/12,2		
K9I□200FV-B			400	50	0,91	4,5/45	1,45/14,5	-	1/10
				60	0,67	4/40	1,22/12,2		
K9I□200FQ-B	415	50	0,62	3,8/38	1,5/15	-	1/10		
		60	0,58	3/30	1,26/12,6				
K9I□200FZ-B	440	50	0,68	4,1/41	1,5/15	-	1/10		
		60	0,54	3/30	1,22/12,2				

\* □ : SHAFT SHAPE ( S : STRAIGHT, P : PINION ) \* FH-B which are in end of the model name is UL certified ones. UL FILE NO. E204632  
 \* 3 phase motor for over 380 voltage can't be used with inverter. Motor winding insulation can be damaged.

### RATED TORQUE OF GEARHEAD

#### ● 50Hz

unit = above : N·m / below : Kgf·cm

Model	Speed(rpm)	500	416	300	250	200	166	150	120	100	83	75	60	50	41	37	30	25	20	16	15	13	10	8,3	7,5
Motor/ Gearhead	Ratio	3	3,6	5	6	7,5	9	10	12,5	15	18	20	25	30	36	40	50	60	75	90	100	120	150	180	200
K9IP200F□-B		3,52	4,23	5,87	7,05	8,81	10,57	11,75	13,21	15,86	19,03	21,14	23,78	28,54	30	30	30	30	30	30	30	30	30	30	30
K9P□BU, BUF		35,2	42,3	58,7	70,5	88,1	105,7	117,5	132,1	158,6	190,3	211,4	237,8	285,4	300	300	300	300	300	300	300	300	300	300	300

#### ● 60Hz

unit = above : N·m / below : Kgf·cm

Model	Speed(rpm)	600	500	360	300	240	200	180	144	120	100	90	72	60	50	45	36	30	24	20	18	15	12	10	9
Motor/ Gearhead	Ratio	3	3,6	5	6	7,5	9	10	12,5	15	18	20	25	30	36	40	50	60	75	90	100	120	150	180	200
K9IP200F□-B		2,96	3,56	4,94	5,93	7,41	8,89	9,88	11,12	13,34	16,01	17,79	20,01	24,01	28,82	30	30	30	30	30	30	30	30	30	30
K9P□BU, BUF		29,6	35,6	49,4	59,3	74,1	88,9	98,8	111,2	133,4	160,1	177,9	200,1	240,1	288,2	300	300	300	300	300	300	300	300	300	300

\* Gearhead and decmal gearhead are sold separately. \* The code in □ of gearhead model is for gear ratio.  
 \*    color indicates that the output shaft of the geared motor rotates in the same direction as the output shaft of the motor. Others indicate rotation in the opposite direction.  
 \* If you are to have less ratio than the ratio in the table, you can install the decmal gearhead, which has one tenth of the ratio, between the gearhead and the motor. In this case, the permissible torque is 30N·m/300kgf·cm.  
 \* RPM is based on motor's synchronous rpm (50HZ:1500rpm, 60HZ:1800rpm) and calculated by dividing gear ratio. Actual rpm is 2~20% less than indicating rpm according to load size.

## GEARHEADS

### CONNECTION DIAGRAMS

three phase motor

Connect Cr circuit for absorbing surge voltage as connection diagram to protect contact point.  
 $R_o = 5 - 200\Omega$   
 $C_o = 0.1 \sim 0.2\mu F$  200WV(400WV)

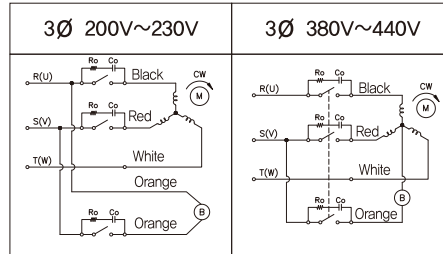

※The direction of motor rotation is as viewed from the front shaft end of the motor

### DIMENSIONS

K9P□BU

K9P□BUF

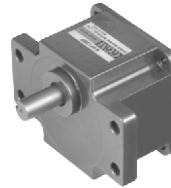
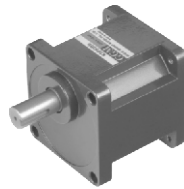

### DECIMAL GEARHEAD

K9P10BX

### KEY SPEC

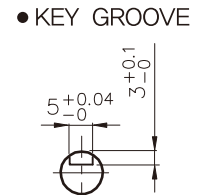
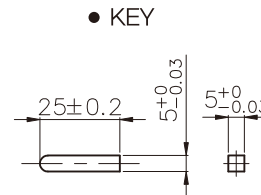
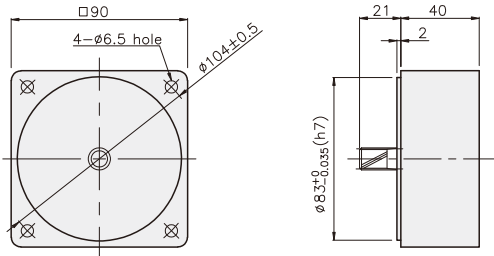

### GEARHEAD

K9P□BU

K9P□BUF

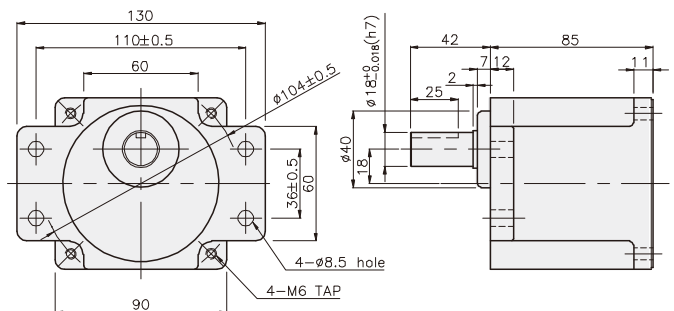
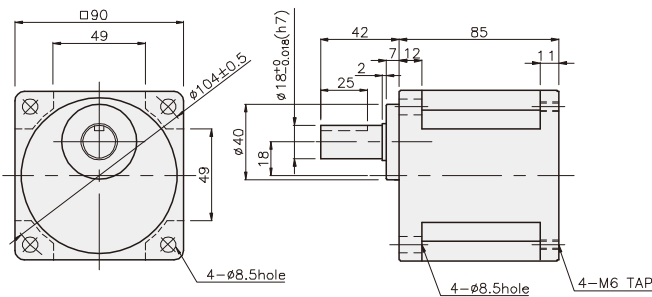

## GEARHEADS

### DIMENSIONS

K9□P200F□ + K9P□BU



K9□P200F□ + K9P□BUF



K9IP200F□-B + K9P□BU

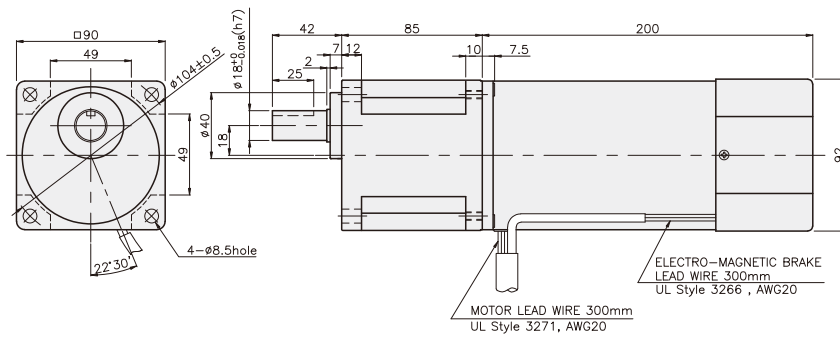

#### WEIGHT

PART	WEIGHT(kg)
MOTOR	4,38
DECIMAL GEAR HEAD	0,62

#### DIMENSION TABLE

PART No	L	Application Model	Mounting BOLT
01	85	K9P3~200BU	M6 P1,0 X 20
02	40	K9P10BX	M6 P1,0 X 60

#### WEIGHT

PART	WEIGHT(kg)
K9P3~10BU	1,44
K9P12,5~20BU	1,55
K9P25~60BU	1,69
K9P75~200BU	1,74

#### DIMENSION TABLE

PART No	L	Application Model	Mounting BOLT
01	85	K9P3~200BUF	M6 P1,0 X 20
02	40	K9P10BX	M6 P1,0 X 65

#### WEIGHT

PART	WEIGHT(kg)
K9P3~10BUF	1,50
K9P12,5~20BUF	1,62
K9P25~60BUF	1,76
K9P75~200BUF	1,82

K9IP200F□-B + K9P□BUF

