

## BRUSHLESS DC MOTOR UNIT - X Series

**200W**  
**400W**

□104mm  
DC 24V, 48V Input

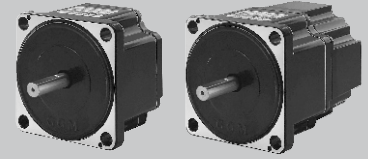

### DIMENSIONS

**K10XS200N2 (24V)**  
**K10XS400N9 (48V)**  
Weight : 2.4Kg

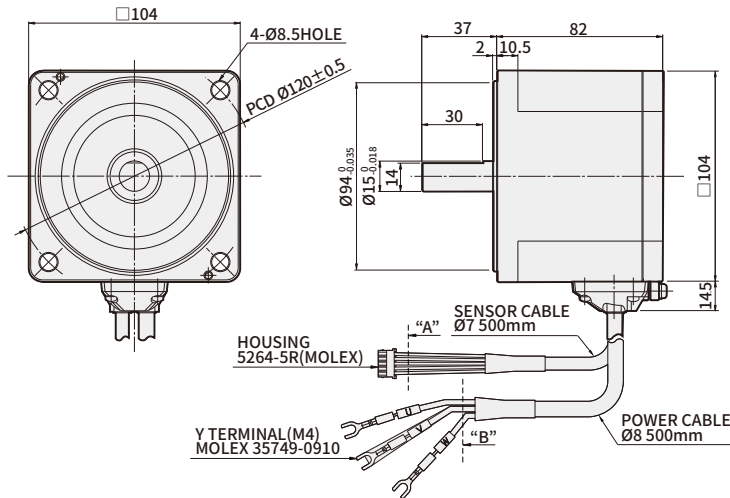

**K10XS200N2-B (Brake type)**  
**K10XS400N9-B**  
Weight : 3Kg

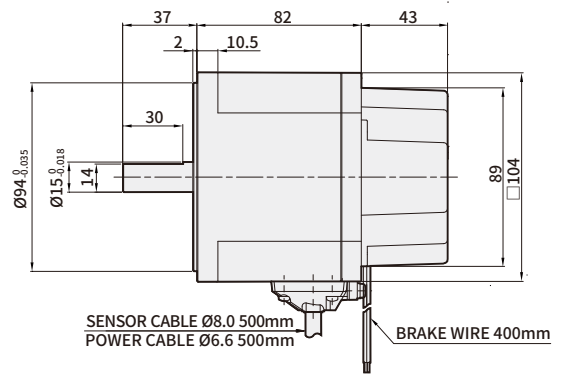

**K10XS200N2-E (Encoder type)**  
**K10XS400N9-E**  
Weight : 2.5Kg

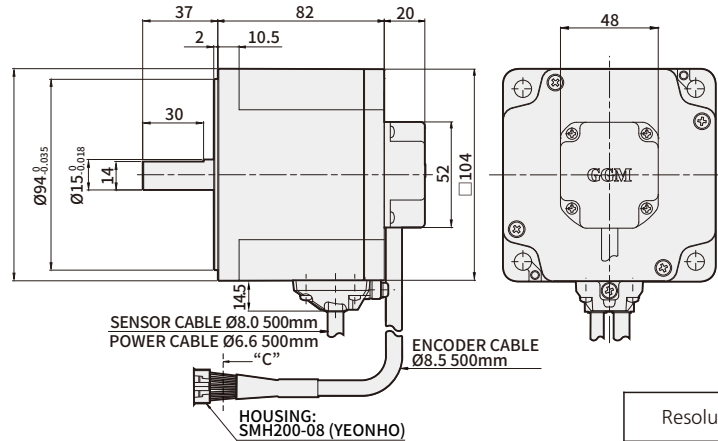

**K10XS200N2-BE (Brake Encoder type)**  
**K10XS400N9-BE**  
Weight : 3.1Kg

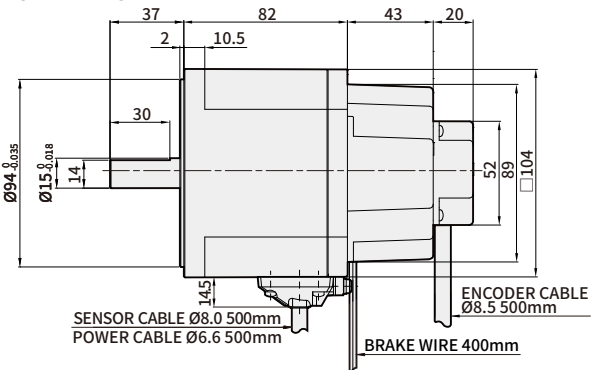

Resolution	1,000PPR		Timing diagram CW A B Z
Output Type	Output Form Line Driver	Power Supply +5Vdc ±10% 150mA below	

※ Please refer to gearhead assembly page C-7, C-8.

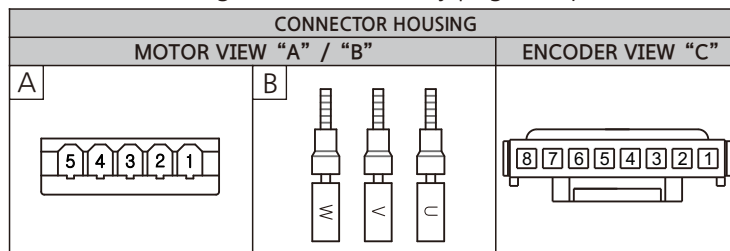

ENCODER PIN MAP		
PIN No.	COLOR	SIGNAL
1	BLUE	Vcc(5Vdc)
2	BROWN	A
3	WHITE	/A
4	ORANGE	B
5	YELLOW	/B
6	GREEN	Z
7	PURPLE	/Z
8	GRAY	Ground

MOTOR PIN MAP		
PIN No.	COLOR	SIGNAL
1	BROWN	Hu
2	WHITE	Hv
3	ORANGE	Hw
4	GREEN	Ground
5	YELLOW	Vcc
-	BLUE	U
-	PURPLE	V
-	GRAY	W

※ 200N2, 400N9 which are in end of the model name is UL certified ones. UL FILE NO. E504659

## → Specification

Product name	GEAR TYPE	K6XH30N2	K8XH50N2	K9XH100N2	K10XH200N2	K10XH400N9
	STRAIGHT TYPE	K6XS30N2	K8XS50N2	K9XS100N2	K10XS200N2	K10XS400N9
Rating output (continuous) W		30	50	100	200	400
Power input	Rating voltage V	DC24				DC 48
	Rating voltage allowance	±10%				
	Rating input current A	2.1	3.1	6	13	11
	Maximum input current A	3.7	5.4	9.8	25	18
Rating torque	N·m(kgf·cm)	0.12	0.2	0.4	0.65	1.3
Starting torque	N·m(kgf·cm)	0.15	0.24	0.5	1.15	1.8
Rating rotation speed	r/min	2500			3000	
Speed control range	r/min	100~3000			100~4000	
Allowed inertia load moment of round shaft type	$J \times 10^{-4} \text{ kg} \cdot \text{m}^2$	1.8	3.3	5.6	8.75	15
Rotor inertia moment	$J \times 10^{-4} \text{ kg} \cdot \text{m}^2$	0.086	0.234	0.61	0.61	0.66
Speed change rate	Load	Less than or equal to ±1% : condition 0-rated torque, rated rotation speed, rated voltage, room temperature				
	Voltage	Less than or equal to ±1% : condition rating voltage ±10%, rating rotation speed, no load, room temperature				
	Temperature	Less than or equal to ±1% : condition surrounding temperature 0~+40°C, rating rotation speed, no load, rating voltage				

- ※ -B (BRAKE), -E (ENCODER) or -BE (BRAKE+ENCODER) can be added to end of the motor model name.
- ※ The usage duration for starting torque is within 5 seconds at less than 2000 r/min.
- ※ Each specification value is the characteristic of motor by itself.

## → Common specifications

Product name	Specification
Rotation speed setting method	<ul style="list-style-type: none"> <li>● Set up by external potentiometer</li> <li>● Set up by external DC 0~5V</li> </ul>
Acceleration time deceleration time	0.5~10 seconds : set at 2000 r/min when there is no load (it may change depending on the size of the load) Acceleration time and deceleration control equipment to control at the same time
Input signal	Internal full-up input method, external input voltage read as greater than 2v high(off) same at all input ports
Protection function	<p>If the following protection mode comes on, control unit alarm signal is shown. Motor stops automatically.</p> <ul style="list-style-type: none"> <li>● Overload protection mode : If torque that is greater than the rating is applied to the motor for more than 5 seconds</li> <li>● Overvoltage protection : If voltage applied to the control unit goes over the upper bound of the rating allowance</li> <li>● Open phase protection : If cable sensor line gets disconnected during motor operation</li> <li>● Undervoltage protection : If voltage applied to the control unit is less than the lower bound of the rating voltage allowance</li> <li>● Over speed protection : If motor rotation speed is faster than 2500 r/min</li> </ul>
Motor insulation class	E TYPE(120°C)
Maximum extension distance	MOTOR - CONTROL UNIT 2m
Rated time	Continuous

- ※ Like weight carried being downwards, X SERIES cannot control motor speed through weight.  
Motor gets stopped automatically through overvoltage protection of load is being carried downwards or it is heavier than allowed load inertia.

## → Normal specifications

Item		Motor	Control unit
Insulation Resistance		After being operated continuously at room temperature and humidity, the value measured between coil and vase by DC 500V MEGA is greater than or equal to 100M $\Omega$	After being operated continuously at room temperature and humidity, the value measured between heatproof plate and power input is greater than or equal to 100M $\Omega$
Dielectric Strength		After being operated continuously at room temperature and humidity, there shouldn't be any problem between coil and case even when AC 0.5kV is applied for 1 minute	No problem when 50Hz, AC 0.5kV is applied for one minute No problem when AC 0.5kV is applied for one minute
Used environment	Used Ambient temperature	0°C~+50°C (should not freeze)	
	Used Ambient Humidity	less than or equal to 85% (not from dews)	
	Vibration	Altitude less than 1000m	
	Ambient environment	Cannot be used under special circumstances such as withcorrosive gas, dust, radioactive material, magnetic and vacuum	
Conservation environment	Vibration	Should not apply constant vibration or huge impact according to the JIS C 60068-2-6 sine wave vibration test method Frequency range : 10~55Hz, peak amplitude : 0.15mm, sweet direction : 3 direction(X,Y,Z), number of sweeps : 20 times	
	Ambient temperature	-25 ~ +70°C (should not freeze)	
	Ambient Humidity	less than or equal to 85% (not form dews )	
		Altitude less than 3000m	
Insulation class		UL, CSA STANDARD A TYPE(105°C), EN STANDARD E TYPE(120°C)	
Protection class		IP65	
		IP00	

- ※ Preservation environment is a short-term value, which includes transportation.
- ※ Do not measure insulation resistance and pressure resistance while motor and driver are connected.

## → Rotation speed- torque characteristic

K6XS30N2 / K6XH30N2

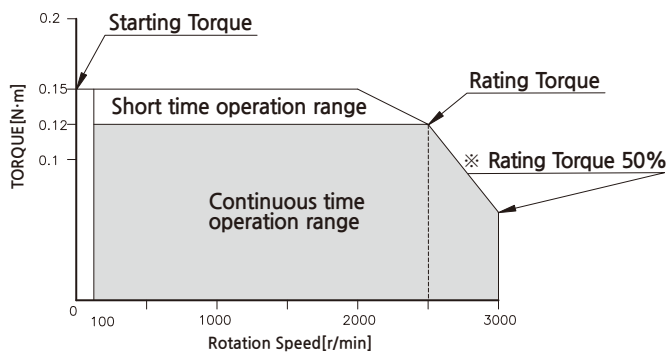

K8XS50N2 / K8XH50N2

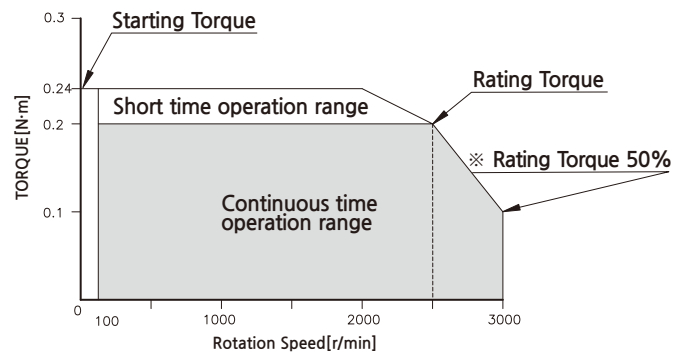

K9XS100N2 / K9XH100N2

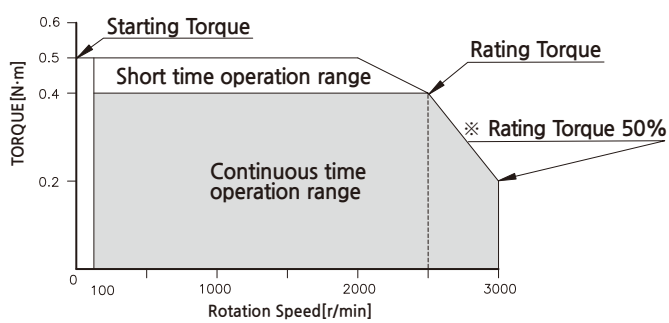

K10XS200N2/K10XH200N2

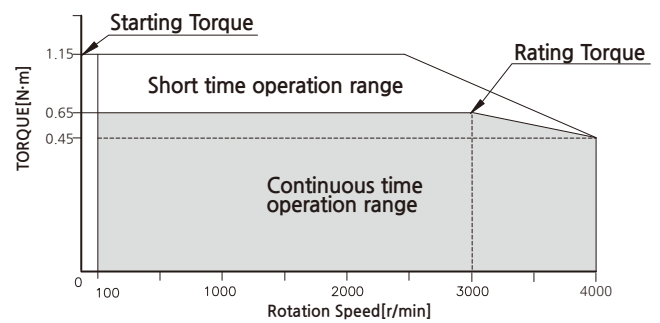

K10XS400N9/K10XH400N9

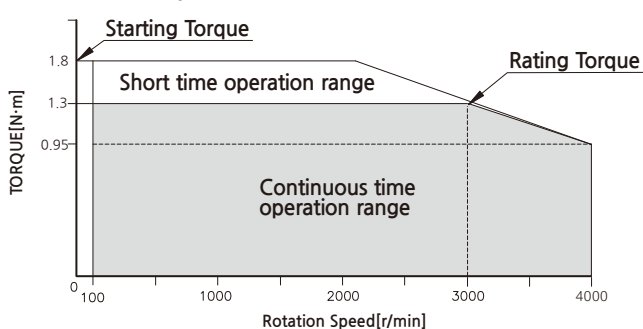

- ※ -B (BRAKE), -E (ENCODER) or -BE (BRAKE+ENCODER) can be added to end of the motor model name.
- ※ DC24V is the value without cable extension.

## BRUSHLESS AC/DC MOTOR UNIT - Gearhead

### DIMENSIONS

## GEARHEAD K10H□B

### K10H□BU

Weight : 3Kg

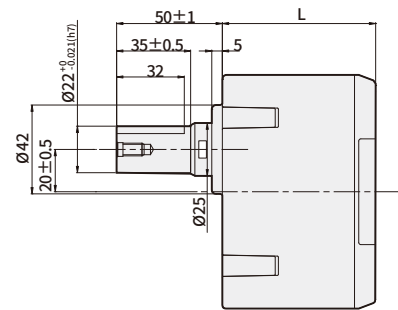
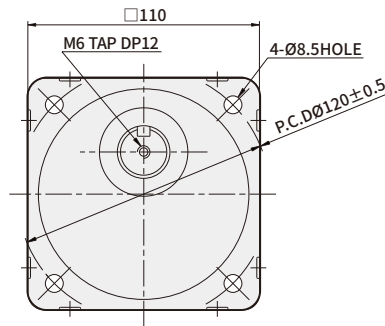

### K10FH200NC + K10H□BU K10FH400NC + K10H□BU K10XH200N2 + K10H□BU K10XH400N9 + K10H□BU

Weight : 5.4Kg

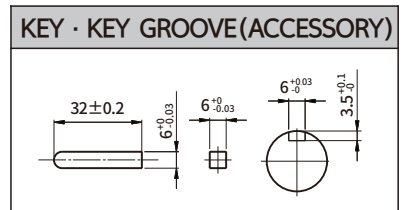
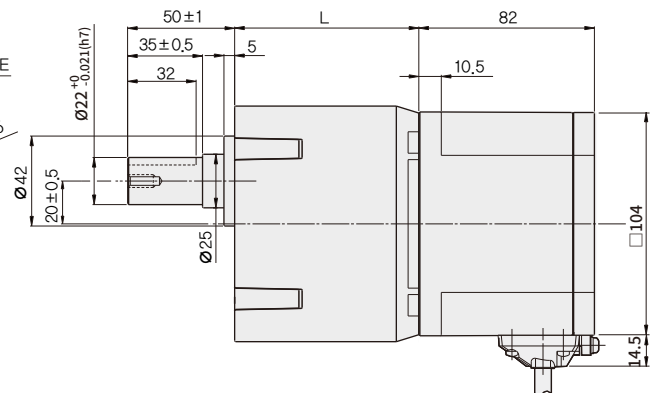
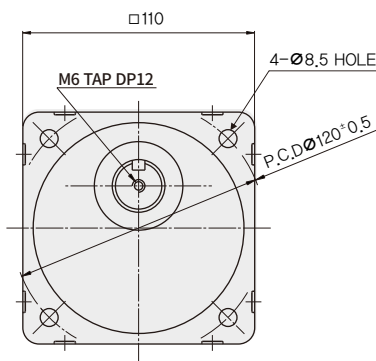

### DIMENSION TABLE

GEARHEAD PRODUCT NAME	DECCELERATION RATIO	L	FIXING BOLT
K10H□BU	5,10,15,20	60	M8 P1.25×95
	30,50	72	M8 P1.25×110
	100,200	86	M8 P1.25×120

※ -B (BRAKE), -E (ENCODER) or -BE (BRAKE+ENCODER) can be added to end of the motor model name.

※ In □ of name, it represents a deceleration ratio.

※ Geared motor is included with fixing bolt set. (flat washer, spring washer, hexagonal nut 4pcs each)

# BRUSHLESS DC MOTOR UNIT - Gearhead

## DIMENSIONS

### GEARHEAD K10H□BTH

**K10H□BTH**  
Weight : 4.9Kg

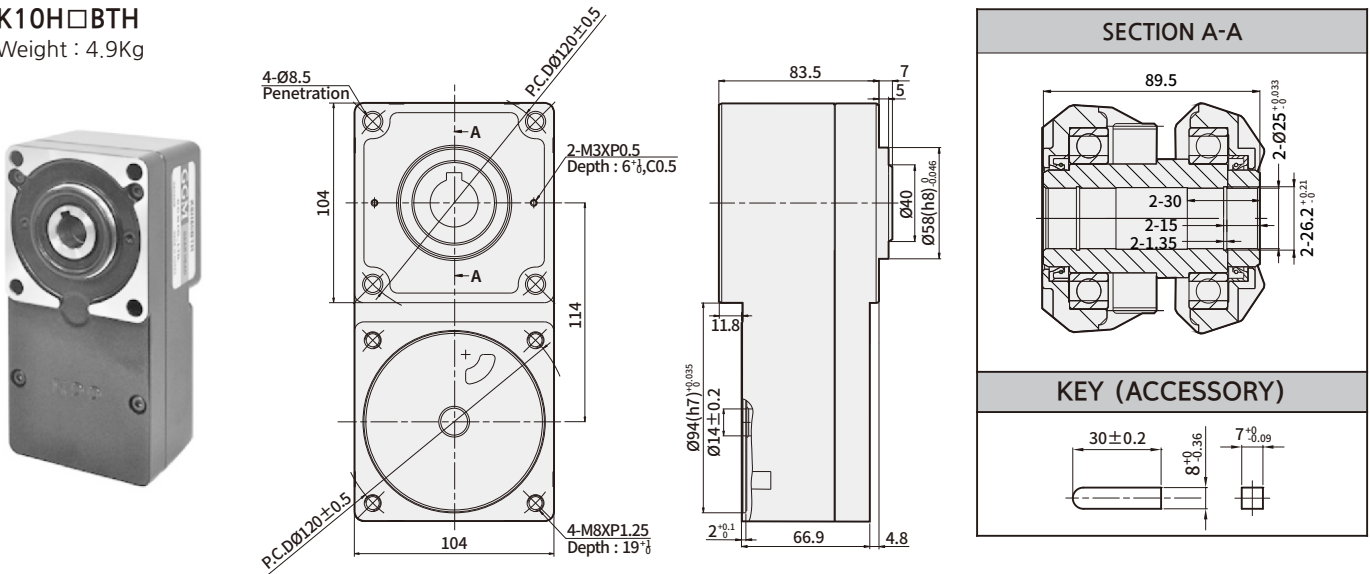

**K10FH200NC + K10H□BTH**  
**K10FH400NC + K10H□BTH**  
**K10XH200N2 + K10H□BTH**  
**K10XH400N9 + K10H□BTH**  
Weight : 7.3Kg

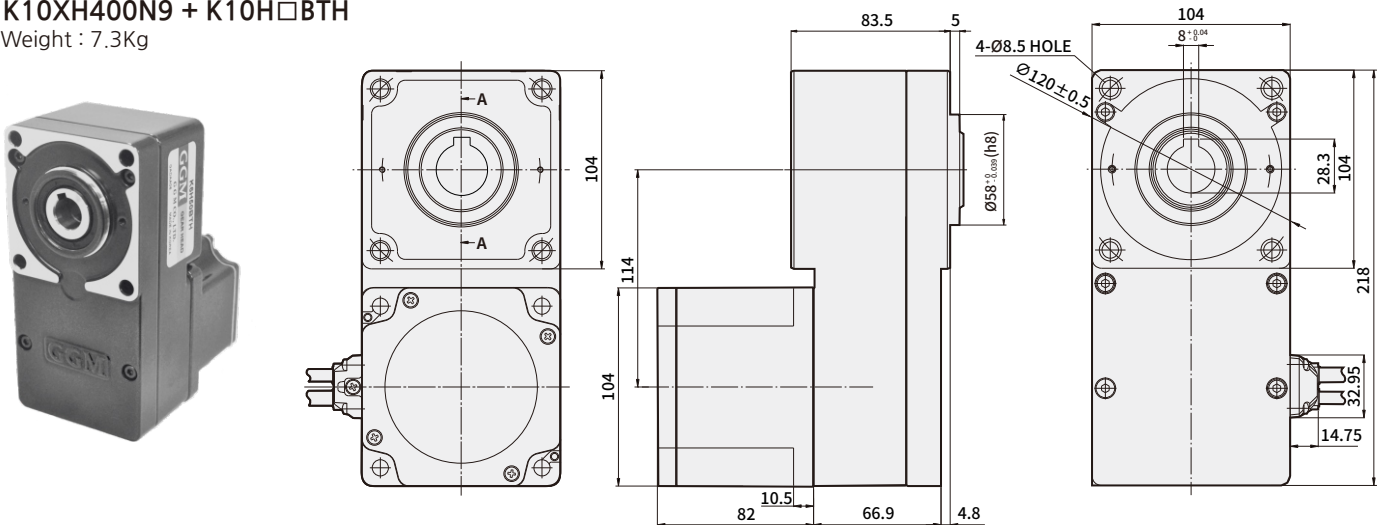

### DIMENSION TABLE

GEARHEAD PRODUCT NAME	DECELERATION RATIO	FIXING BOLT
K10H□BTH	5, 10, 15, 20, 30 50, 100	M8 P1.25×100

- ※ -B (BRAKE), -E (ENCODER) or -BE (BRAKE+ENCODER) can be added to end of the motor model name.
- ※ In □ of name, it represents a deceleration ratio.
- ※ Geared motor is included with fixing bolt set. (flat washer, spring washer, hexagonal nut 4pcs each)

## → Delivery efficiency of gearhead

Product name	Deceleration ratio	5	10	15	20	30	50	100	200
	K6H□B		90%				86%		
K8H□B		90%				86%			81%
K9H□B		90%				86%			81%
K10H□BU		90%				86%		81%	
K6H□BTH		80%	85%						
K8H□BTH		85%							
K9H□BTH		85%							
K10H□BTH		85%							

## → Allowed torque of AC Motor + Gearhead

Unit = N·m

Product name	Deceleration ratio	5	10	15	20	30	50	100	200
	Speed control range[r/min]	20~600	10~300	6.7~200	5~150	3.3~100	2~60	1~30	0.5~15
K6BH30N■ + K6H□B	100~3000	0.45	0.9	1.4	1.8	2.6	4.3	6	6
K8BH60N■ + K8H□B		0.9	1.8	2.7	3.6	5.2	8.6	16	16
K9BH90N■ + K9H□B		1.35	2.7	4.1	5.4	7.7	12.9	25.8	30
K9BH150NC + K9H□B		2.2	4.4	6.6	8.8	12.6	21.1	30	30
K6BH30N■ + K6H□BTH		0.4	0.85	1.3	1.7	2.6	4.3	8.5	17
K8BH60N■ + K8H□BTH		0.85	1.7	2.6	3.4	5.1	8.5	17	34
K9BH90N■ + K9H□BTH		1.9	3.8	5.7	7.7	11.5	19.1	38.3	68
K9BH150NC + K9H□BTH		2.1	4.2	6.2	8.3	12.5	21	42	68
Product name	Deceleration ratio	5	10	15	20	30	50	100	200
	Speed control range[r/min]	20~800	10~400	6.7~266	5~200	3.3~133	2~80	1~40	0.5~20
K6FH30NC+K6H□B	100~3000	0.45	0.9	1.4	1.8	2.6	4.3	6	6
	4000	0.36	0.72	1.08	1.4	2.1	3.4	5.4	5.4
K8FH60NC+K8H□B	100~3000	0.9	1.8	2.7	3.6	5.2	8.6	16	16
	4000	0.68	1.4	2.0	2.7	3.9	6.5	12.9	14
K9FH150NC+K9H□B	100~3000	2.2	4.4	6.6	8.8	12.6	21.1	30	30
	4000	1.4	2.7	4.1	5.4	7.7	12.9	25.8	27
K10FH200NC+K10H□BU	100~3000	2.9	5.9	8.8	11.7	16.8	28	52.7	70
	4000	2	4.1	6.1	8.1	11.6	19.4	36.5	63
K10FH400NC+K10H□BU	100~3000	5.9	11.7	17.6	23.4	33.5	55.9	70	70
	4000	4.3	8.6	12.8	17.1	24.5	40.9	63	63
K6FH30NC+K6H□BTH	100~3000	0.4	0.85	1.3	1.7	2.6	4.3	8.5	17
	4000	0.30	0.64	0.96	1.3	1.9	3.2	6.4	12.8
K8FH60NC+K8H□BTH	100~3000	0.85	1.7	2.6	3.4	5.1	8.5	17	34
	4000	0.64	1.3	1.9	2.6	3.8	6.4	12.8	25.5
K9FH150NC+K9H□BTH	100~3000	2.1	4.2	6.2	8.3	12.5	21	42	68
	4000	1.3	2.6	3.8	5.1	7.7	12.8	25.5	51
K10FH200NC+K10H□BTH	100~3000	2.8	5.5	8.3	11.1	16.6	27.6	55.3	—
	4000	1.9	3.8	5.7	7.7	11.5	19.1	38.3	—
K10FH400NC+K10H□BTH	100~3000	5.5	11.1	16.6	22.1	33.2	55.3	110	—
	4000	4.0	8.1	12.1	16.2	24.2	40.4	80.8	—

- \* -B (BRAKE), -E (ENCODER) or -BE (BRAKE+ENCODER) can be added to end of the motor model name.
- \* In ■ of the model name voltage U (single-phase 100~115V), C (single-phase 200~230V) will be shown.
- \* In □ of name, it represents a deceleration ratio.
- \* Rotation direction shows the same [ ] color as the motor. In other cases, it's the opposite.
- \* Flat Gearbox viewed from front side is opposite rotation direction with motor.
- \* Flat Gearbox viewed from back side is same rotation direction with motor.

## → Allowed torque of DC Motor + Gearhead

Unit = N·m

Product name	Deceleration ratio	5	10	15	20	30	50	100	200
	Speed control range[r/min]	20~600	10~300	6.7~200	5~150	3.3~100	2~60	1~30	0.5~15
K6XH30N2 + K6H□B	100~2500	0.54	1.1	1.6	2.2	3.1	5.2	6	6
	3000	0.3	0.54	0.81	1.1	1.5	2.6	5.2	6
K8XH50N2 + K8H□B	100~2500	0.9	1.8	2.7	3.6	5.2	8.6	16	16
	3000	0.45	0.9	1.4	1.8	2.6	4.3	8.6	16
K9XH100N2 + K9H□B	100~2500	1.8	3.6	5.4	7.2	10.3	17.2	30	30
	3000	0.9	1.8	2.7	3.6	5.2	8.6	17.2	30
K6XH30N2 + K6H□BTH	100~2500	0.48	1	1.5	2	3.1	5.1	10.2	17
	3000	0.2	0.51	0.77	1	1.5	2.6	5.1	10.2
K8XH50N2 + K8H□BTH	100~2500	0.85	1.7	2.6	3.4	5.1	8.5	17	34
	3000	0.43	0.85	1.3	1.7	2.6	4.3	8.5	17
K9XH100N2 + K9H□BTH	100~2500	1.7	3.4	5.1	6.8	10.2	17	34	68
	3000	0.85	1.7	2.6	3.4	5.1	8.5	17	34
Product name	Deceleration ratio	5	10	15	20	30	50	100	200
	Speed control range[r/min]	20~800	10~400	6.7~267	5~200	3.3~133	2~80	1~40	0.5~20
K10XH200N2 + K10H□BU	100~3000	2.9	5.9	8.8	11.7	16.8	28	52.7	70
	4000	2.0	4.1	6.1	8.1	11.6	19.4	36.5	63
K10XH400N9 + K10H□BU	100~3000	5.9	11.7	17.6	23.4	33.5	55.9	70	70
	4000	4.3	8.6	12.8	17.1	24.5	40.9	63	63
K10XH200N2 + K10H□BTH	100~3000	2.8	5.5	8.3	11.1	16.6	27.6	55.3	—
	4000	1.9	3.8	5.7	7.7	11.5	19.1	38.3	—
K10XH400N9 + K10H□BTH	100~3000	5.5	11.1	16.6	22.1	33.2	55.3	110	—
	4000	4.0	8.1	12.1	16.2	24.2	40.4	80.8	—

※ -B (BRAKE), -E (ENCODER) or -BE (BRAKE+ENCODER) can be added to end of the motor model name.

※ In □ of name, it represents a deceleration ratio.

※ Rotation direction shows the same  color as the motor. In other cases, it's the opposite.

※ Flat Gearbox viewed from front side is opposite rotation direction with motor. Flat Gearbox viewed from back side is same rotation direction with motor.

## → Allowed overhang load and allowed thrust

Product name		Deceleration ratio	Allowed overhang load				Allowed thrust load	
			From the end of output part 10mm		From the end of output part 20mm		N	kgf
			N	kgf	N	kgf		
GEARHEAD	K6H□B	5	100	10	150	15	40	4
		10,15,20	150	15	200	20		
		30,50,100,200	200	20	300	30		
	K8H□B	5	200	20	250	25	100	10
		10,15,20	300	30	350	35		
		30,50,100,200	450	45	550	55		
	K9H□B	5	300	30	400	40	150	15
		10,15,20	400	40	500	50		
		30,50,100,200	500	50	650	65		
	K10H□BU	5,10,15,20	550	55	800	80	200	20
		30,50	1000	100	1250	125	300	30
		100,200	1400	140	1700	170	400	40
	K6H□BTH	5,10	450	45	370	37	200	20
		15~200	500	50	400	40		
	K8H□BTH	5,10	800	80	660	66	400	40
		15~200	1200	120	1000	100		
	K9H□BTH	5,10	900	90	770	77	500	50
		15,20	1300	130	1110	111		
		30,50,100,200	1500	150	1280	128		
	K10H□BTH	5,10	1230	123	1070	107	800	80
		15,20	1680	168	1470	147		
30,50,100		2040	204	1780	178			
MOTOR	K6BS30N■,K6FS30NC K6XS30N2		70	7	100	10	· Do not apply THRUST load Please. If you can't help it, 50% or less.	
	K8BS60N■,K8FS60NC K8XS50N2		120	12	140	14		
	K9BS90N■,K9BS150NC K9FS150NC,K9XS100N2		160	16	170	17		
	K10FS200NC,K10FS400NC K10XS200N2,K10XS400N9		197	19.7	220	22		

- ※ -B (BRAKE), -E (ENCODER) or -BE (BRAKE+ENCODER) can be added to end of the motor model name.
- ※ In ■ of the model name voltage U (single-phase 100~115V), C (single-phase 200~230V) will be shown.
- ※ In □ of name, it represents a deceleration ratio.
- ※ Permissible overhang load can be withdrawn by calculation.