

## SPEED CONTROL MOTOR - SP SERIES

**90W**

□90mm

INDUCTION MOTOR

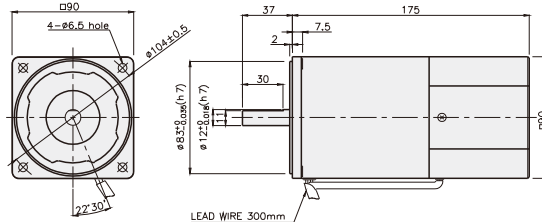

### SPECIFICATIONS

90W continuous rating, four poles

Model	Voltage (V)	Frequency (Hz)	Speed Range (rpm)	Permissible Torque		Start T. (N*m/Kgf*cm)	Current (A)	Condenser (μF)
				1200rpm (N*m/Kgf*cm)	90rpm (N*m/Kgf*cm)			
K9I□90FJ-SP	100	50	90 ~ 1400	0.7/7	0.23/2.3	0.36/3.6	3.2	30
			90 ~ 1700					
K9I□90FU-SP	110	60	90 ~ 1700	0.7/7	0.23/2.3	0.35/3.5	2.6	20
			115					
K9I□90FL-SP	200	50	90 ~ 1400	0.73/7.3	0.23/2.3	0.36/3.6	1.3	7
			90 ~ 1700		0.26/2.6			
K9I□90FC-SP	220	50	90 ~ 1400	0.73/7.3	0.23/2.3	0.36/3.6	1.1	6
			90 ~ 1700		0.26/2.6			
	230	50	90 ~ 1400		0.23/2.3	0.4/4	1.2	
			90 ~ 1700		0.26/2.6			
K9I□90FD-SP	240	50	90 ~ 1400	0.73/7.3	0.23/2.3	0.36/3.6	1.2	5

\* □ : SHAFT SHAPE ( S : STRAIGHT, P : PINION )

### RATED TORQUE OF GEARHEAD

#### ● Single-phase 100V/115V

unit = above : N·m / below : Kgf·cm

Model/Gearhead	Ratio Speed(rpm)	Ratio																							
		3	3.6	5	6	7.5	9	10	12.5	15	18	20	25	30	36	40	50	60	75	90	100	120	150	180	200
K9I□90F□-SP K9P□B, BF	1200	1.70 17.0	2.04 20.4	2.84 28.4	3.40 34.0	4.25 42.5	5.10 51.0	5.67 56.7	6.38 63.8	7.65 76.5	9.19 91.9	10.21 102.1	11.48 114.8	13.78 137.8	16.53 165.3	18.37 183.7	20 200	20 200	20 200	20 200	20 200	20 200	20 200	20 200	20 200
	90	0.56 5.6	0.67 6.7	0.93 9.3	1.12 11.2	1.40 14.0	1.68 16.8	1.86 18.6	2.10 21.0	2.52 25.2	3.02 30.2	3.35 33.5	3.77 37.7	4.53 45.3	5.43 54.3	6.04 60.4	7.55 75.5	9.05 90.5	10.19 101.9	12.22 122.2	13.58 135.8	16.30 163.0	20 200	20 200	20 200

#### ● Single-phase 200V/240V

unit = above : N·m / below : Kgf·cm

Model/Gearhead	Ratio Speed(rpm)	Ratio																							
		3	3.6	5	6	7.5	9	10	12.5	15	18	20	25	30	36	40	50	60	75	90	100	120	150	180	200
K9I□90F□-SP K9P□B, BF	1200	1.77 17.7	2.13 21.3	2.96 29.6	3.55 35.5	4.43 44.3	5.32 53.2	5.91 59.1	6.65 66.5	7.98 79.8	9.58 95.8	10.64 106.4	11.97 119.7	14.37 143.7	17.24 172.4	19.16 191.6	20 200	20 200	20 200	20 200	20 200	20 200	20 200	20 200	20 200
	90	200V/220V/230V 240V/50Hz	0.56 5.6	0.67 6.7	0.93 9.3	1.12 11.2	1.40 14.0	1.68 16.8	1.86 18.6	2.10 21.0	2.52 25.2	3.02 30.2	3.35 33.5	3.77 37.7	4.53 45.3	5.43 54.3	6.04 60.4	7.55 75.5	9.05 90.5	10.19 101.9	12.22 122.2	13.58 135.8	16.30 163.0	20 200	20 200
		200V/220V 230V/60Hz	0.63 6.3	0.76 7.6	1.05 10.5	1.26 12.6	1.58 15.8	1.90 19.0	2.11 21.1	2.37 23.7	2.84 28.4	3.41 34.1	3.79 37.9	4.26 42.6	5.12 51.2	6.14 61.4	6.82 68.2	8.53 85.3	10.24 102.4	11.51 115.1	13.82 138.2	15.35 153.5	18.42 184.2	20 200	20 200

- \* Gearhead and decimal gearhead are sold separately.
- \* The code in □ of gearhead model is for gear ratio.
- \* ■ color indicates that the output shaft of the geared motor rotates in the same direction as the output shaft of the motor, Others indicate rotation in the opposite direction.
- \* If you are to have less ratio than the ratio in the table, you can install the decimal gearhead, which has one tenth of the ratio, between the gearhead and the motor. In this case, the permissible torque is 20N·m/200kgf·cm.
- \* RPM is based on motor's synchronous rpm (50HZ:1500rpm, 60HZ:1800rpm) and calculated by dividing gear ratio. Actual rpm is 2~20% less than indicating rpm according to load size.

SPEED CONTROL MOTOR - SP SERIES

## GEARHEADS

### RATED TORQUE OF GEARHEAD

#### ● Single-phase 100V/115V

unit = above : N · m / below : kgfcm

Model Motor/Gearhead	Ratio Speed(rpm)	3	3,6	5	6	7,5	9	10	12,5	15	18	20	25	30	36	40	50	60	75	90	100	120	150	180	200
		K9I□90F□-SP K9P□BU, BUF	1200	1,70 17,0	2,04 20,4	2,84 28,4	3,40 34,0	4,25 42,5	5,10 51,0	5,67 56,7	6,38 63,8	7,65 76,5	9,91 99,1	10,21 102,1	11,48 114,8	13,78 137,8	16,53 165,3	18,37 183,7	22,96 229,6	27,56 275,6	30 300	30 300	30 300	30 300	30 300
90	0,56 5,6		0,67 6,7	0,93 9,3	1,12 11,2	1,40 14,0	1,68 16,8	1,86 18,6	2,10 21,0	2,52 25,2	3,02 30,2	3,35 33,5	3,77 37,7	4,53 45,3	5,43 54,3	6,04 60,4	7,55 75,5	9,05 90,5	10,19 101,9	12,22 122,2	13,58 135,8	16,30 163,0	20,37 203,7	24,45 244,5	27,16 271,6

#### ● Single-phase 200V/240V

unit = above : N · m / below : kgfcm

Model Motor/Gearhead	Ratio Speed(rpm)	3	3,6	5	6	7,5	9	10	12,5	15	18	20	25	30	36	40	50	60	75	90	100	120	150	180	200	
		K9I□90F□-SP K9P□BU, BUF	1200	1,77 17,7	2,13 21,3	2,96 29,6	3,55 35,5	4,43 44,3	5,32 53,2	5,91 59,1	6,65 66,5	7,98 79,8	9,58 95,8	10,64 106,4	11,97 119,7	14,37 143,7	17,24 172,4	19,16 191,6	23,95 239,5	28,74 287,4	30 300	30 300	30 300	30 300	30 300	30 300
90	200V/220V/230V 240V/50Hz		0,56 5,6	0,67 6,7	0,93 9,3	1,12 11,2	1,40 14,0	1,68 16,8	1,86 18,6	2,10 21,0	2,52 25,2	3,02 30,2	3,35 33,5	3,77 37,7	4,53 45,3	5,43 54,3	6,04 60,4	7,55 75,5	9,05 90,5	10,19 101,9	12,22 122,2	13,58 135,8	16,30 163,0	20,37 203,7	24,45 244,5	27,16 271,6
	200V/220V 230V/60Hz		0,63 6,3	0,76 7,6	1,05 10,5	1,26 12,6	1,58 15,8	1,90 19,0	2,11 21,1	2,37 23,7	2,84 28,4	3,41 34,1	3,79 37,9	4,26 42,6	5,12 51,2	6,14 61,4	6,82 68,2	8,53 85,3	10,24 102,4	11,51 115,1	13,82 138,2	15,35 153,5	18,42 184,2	23,03 230,3	27,63 276,3	30 300

- \* Gearhead and decimal gearhead are sold separately.
- \* The code in □ of gearhead model is for gear ratio.
- \*  color indicates that the output shaft of the geared motor rotates in the same direction as the output shaft of the motor. Others indicate rotation in the opposite direction.
- \* If you are to have less ratio than the ratio in the table, you can install the decimal gearhead, which has one tenth of the ratio, between the gearhead and the motor. In this case, the permissible torque is  $30N \cdot m/300kgfcm$ .
- \* RPM is based on motor's synchronous rpm (50HZ:1500rpm, 60HZ:1800rpm) and calculated by dividing gear ratio. Actual rpm is 2~20% less than indicating rpm according to load size.

### CONNECTION DIAGRAMS

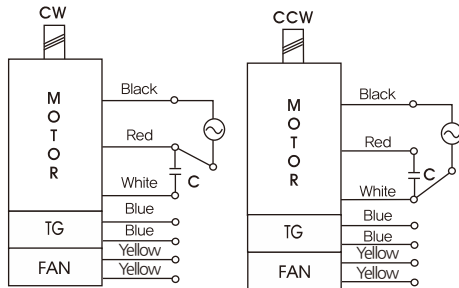

※The direction of motor rotation is as viewed from the front shaft end of the motor

## GEARHEADS

### DIMENSIONS

K9P□B



K9P□BF, BUF



K9P□BU

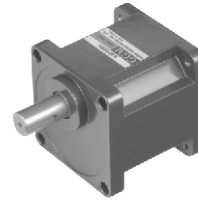

### DECIMAL GEARHEAD

K9P10BX

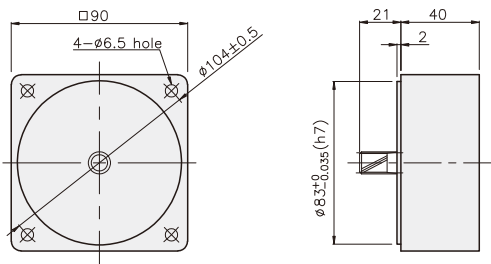

### KEY SPEC

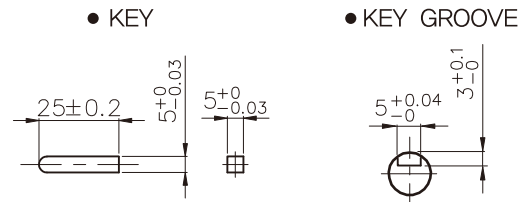

### GEARHEAD

K9P□B

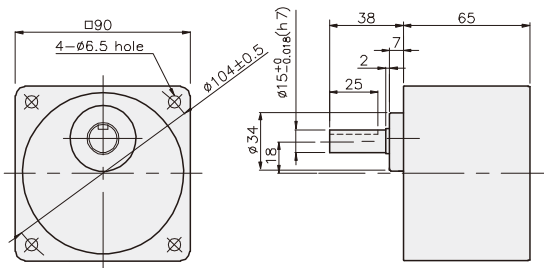

K9P□BF

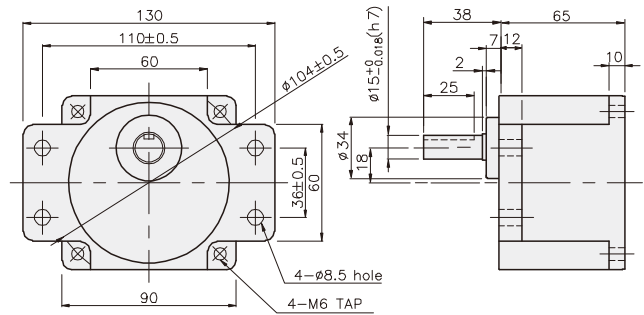

K9P□BU

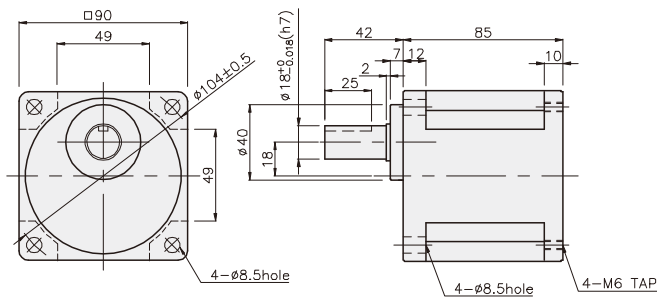

K9P□BUF

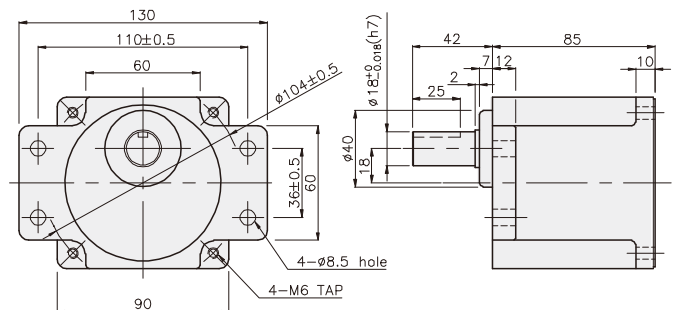

## GEARHEADS

### DIMENSIONS

K9IP90F□-SP + K9P□B



K9IP90F□-SP + K9P□BF, BUF



K9IP90F□-SP + K9P□BU

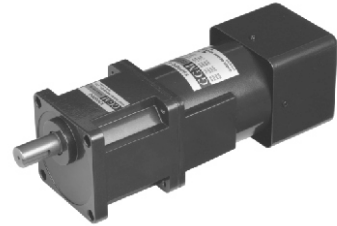

K9IP90F□-SP + K9P□B

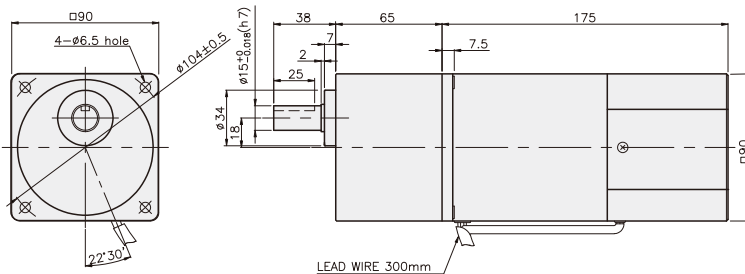

#### WEIGHT

PART	WEIGHT(kg)
MOTOR	3,58
DECIMAL GEAR HEAD	0,62

#### DIMENSION TABLE

PART No.	L	Application Model	Mounting BOLT
01	65	K9P3~200B	M6 P1,0 X 95
02	40	K9P10BX	M6 P1,0 X 140

#### WEIGHT

PART	WEIGHT(kg)
K9P3~10B	1,22
K9P12,5~20B	1,32
K9P25~60B	1,42
K9P75~200B	1,45

#### DIMENSION TABLE

PART No.	L	Application Model	Mounting BOLT
01	65	K9P3~200BF	M6 P1,0 X 25
02	40	K9P10BX	M6 P1,0 X 65

#### WEIGHT

PART	WEIGHT(kg)
K9P3~10BF	1,22
K9P12,5~20BF	1,30
K9P25~60BF	1,42
K9P75~200BF	1,44

#### DIMENSION TABLE

PART No.	L	Application Model	Mounting BOLT
01	85	K9P3~200BU	M6 P1,0 X 20
02	40	K9P10BX	M6 P1,0 X 60

#### WEIGHT

PART	WEIGHT(kg)
K9P3~10BU	1,44
K9P12,5~20BU	1,55
K9P25~60BU	1,69
K9P75~200BU	1,74

#### DIMENSION TABLE

PART No.	L	Application Model	Mounting BOLT
01	85	K9P3~200BUF	M6 P1,0 X 20
02	40	K9P10BX	M6 P1,0 X 65

#### WEIGHT

PART	WEIGHT(kg)
K9P3~10BUF	1,50
K9P12,5~20BUF	1,62
K9P25~60BUF	1,76
K9P75~200BUF	1,82

K9IP90F□-SP + K9P□BF

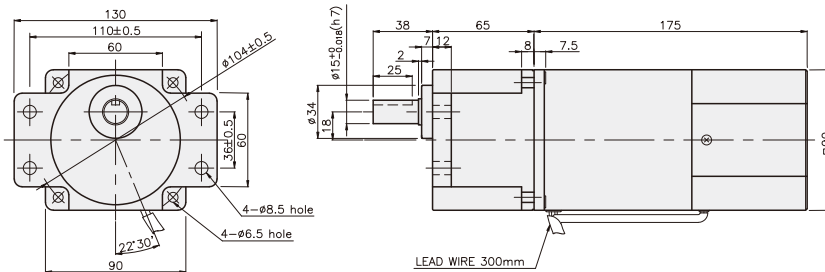

K9IP90F□-SP + K9P□BU

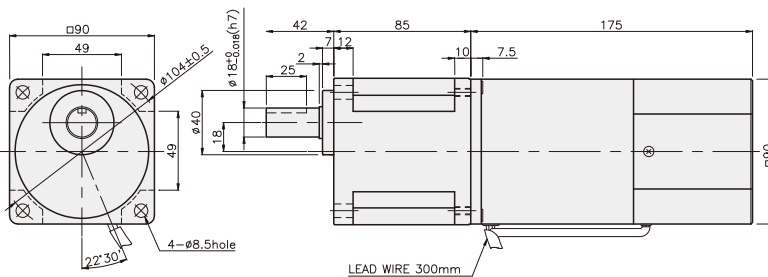

K9IP90F□-SP + K9P□BUF

