

No.	REMARK	REVISION No.	SIGN

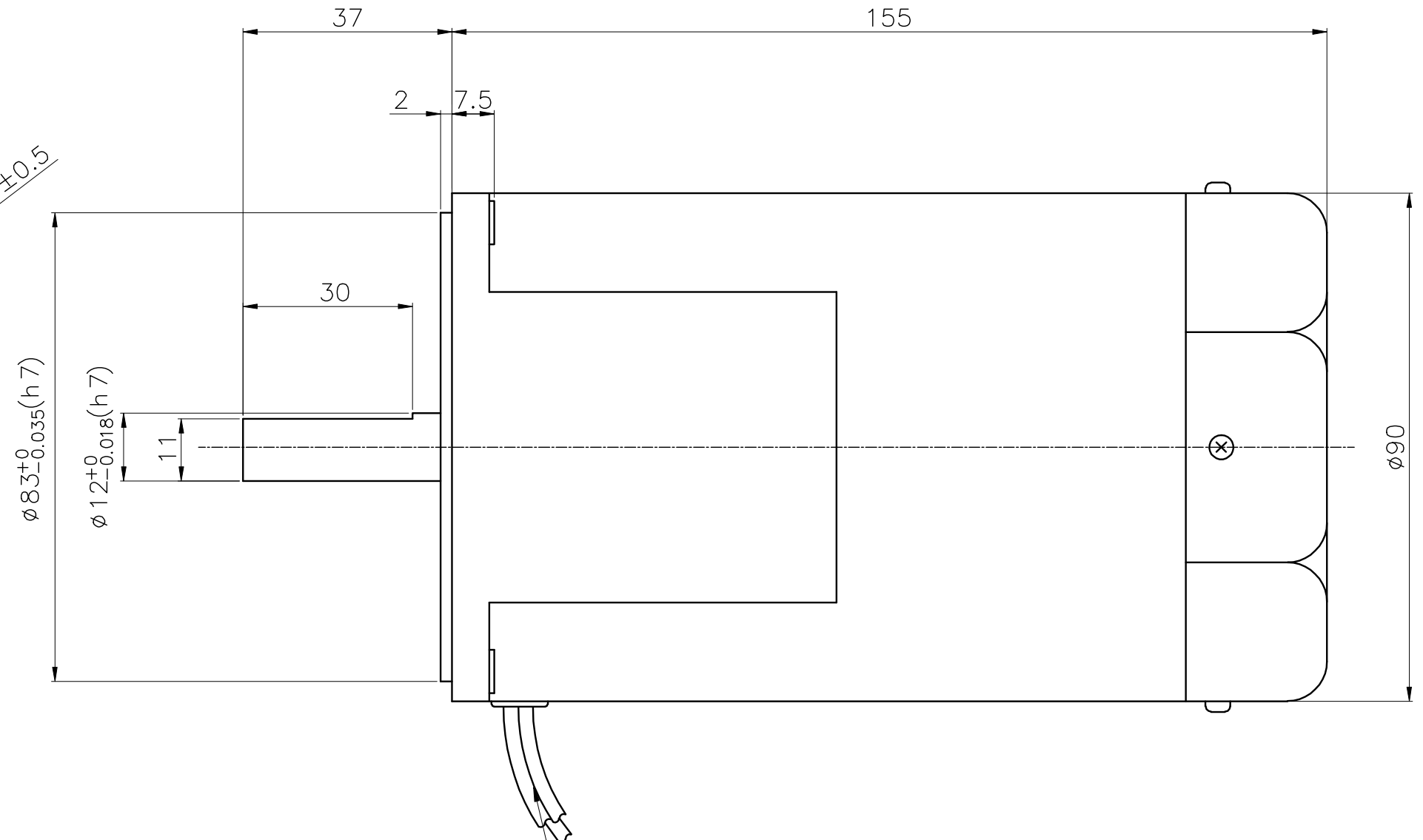
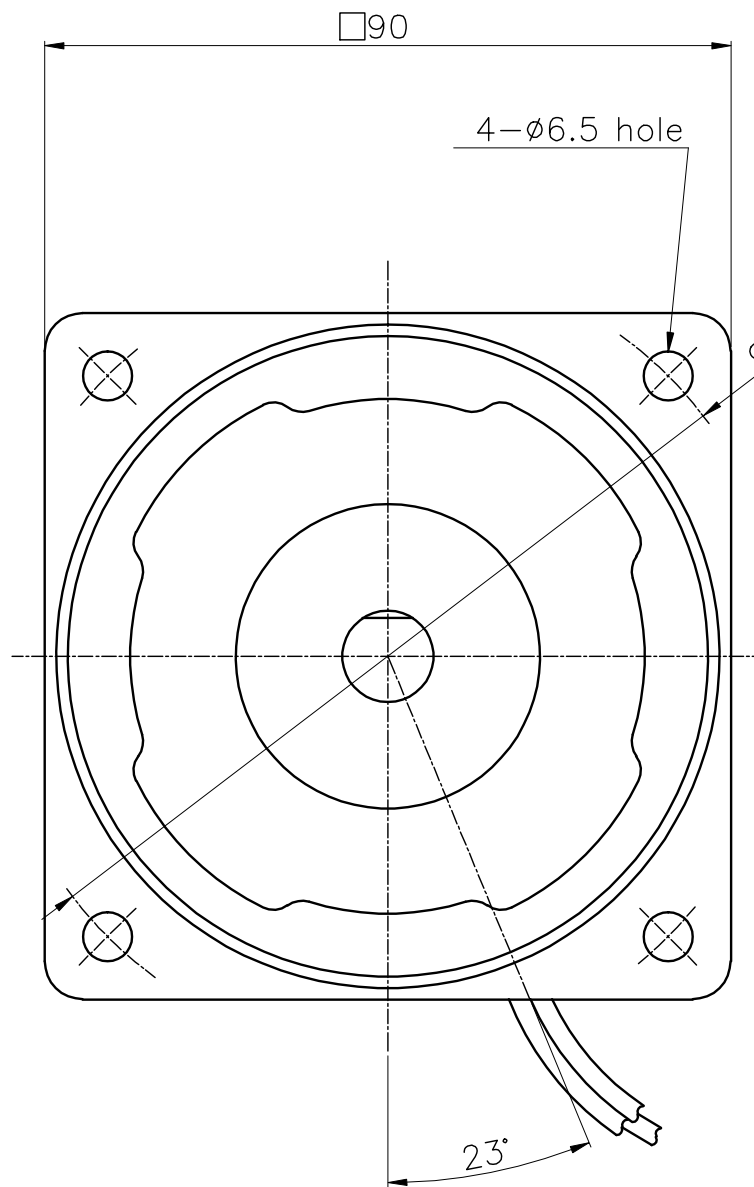

MOTOR LEAD WIRE 300mm
UL Style 3271, AWG20

DRAW	12. 11. 7	SCALE : 1/1	PART NAME
DESIGNED		UNIT : mm	OUTLINE
CHECKED			APPLICATION MODEL
APPROVED			K9IS180F□ , K9IS180F□ -2P, K9RS180F□ K9IS200F□ , K9IS200F□ -2P
		RELATION DWG.	DWG NO. 2-OL-00033