

KGP-TYPE(FLANGE)

DIMENSIONS

KGP-3429 SERIES

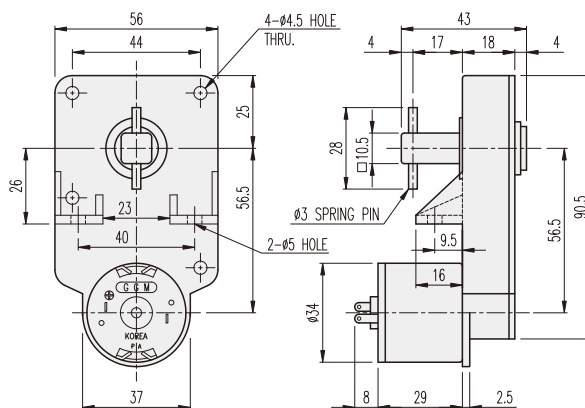

KGP-3448 SERIES

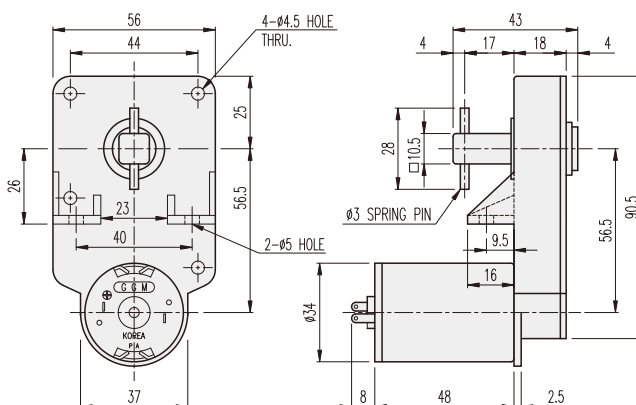

AT MAXIMUM EFFICIENCY (KGP-□□□□-KD3429□□)

GEAR	MODEL		KD3429S1		KD3429S2		KD3429T1		KD3429T2		KD3429P1		KD3429P2	
	DC 12V		DC 24V		DC 12V		DC 24V		DC 12V		DC 24V		DC 24V	
	rpm	kgf-cm	rpm	kgf-cm	rpm	kgf-cm	rpm	kgf-cm	rpm	kgf-cm	rpm	kgf-cm	rpm	kgf-cm
1/0062	72.6	1.5	72.6	1.5	104.8	1.5	104.8	1.5	129	3.2	129	1.5	1.5	1.5
1/0116	38.8	2.7	38.8	2.7	56	2.7	56	2.7	69	6	69	2.7	2.7	2.7

AT MAXIMUM EFFICIENCY (KGP-□□□□-KD3448□□)

GEAR	MODEL		KD3448S1		KD3448S2		KD3448T1		KD3448T2		KD3448P1		KD3448P2	
	DC 12V		DC 24V		DC 12V		DC 24V		DC 12V		DC 24V		DC 24V	
	rpm	kgf-cm	rpm	kgf-cm	rpm	kgf-cm	rpm	kgf-cm	rpm	kgf-cm	rpm	kgf-cm	rpm	kgf-cm
1/0062	72.6	3.2	72.6	3.2	104.8	3.2	104.8	3.2	129	3.2	129	3.2	3.2	3.2
1/0116	38.8	6	38.8	6	56	6	56	6	69	6	69	6	6	6

※ 減速比全体モーターと出力軸の回転方向は同じです。

KD□-34□□-TYPE

DIMENSIONS

KD3429□□ SERIES



KD3448□□ SERIES

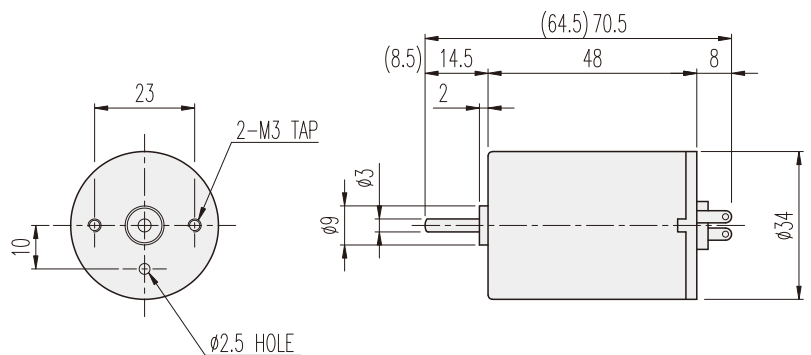

ENCODER SERIES

KD3429□□-E & 3448□□-E



6P-CONNECTOR 結線内容

No.1	接続内容	備考
1	DC MOOTR (+) 電源	電源投入時 MOTOR CCW回転
2	DC MOOTR (-) 電源	
3	H/SENSOR (+) 電源	Vcc (+) DC 5 ~ 24V
4	H/SENSOR (-) 電源	GROUND
5	H/SENSOR #1 OUT	OPEN COLLECTOR MAX. DC 24V -50mA
6	H/SENSOR #1 OUT	

20ポール10パルス INCREMENTAL TYPE

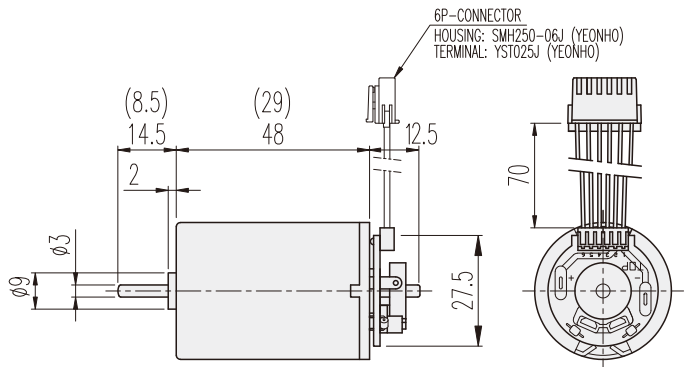

PERFORMANCE DATA

MODEL	ITEM	VOLTAGE (DC)	NO LOAD		AT MAX. EFF.		STALL		WEIGHT (g)
			mA	rpm	gf-cm	A	rpm	A	
90	KD3429S1	12V	120	5200	40	0.3	4500	1.7	360
	KD3429S2	24V	70	5200	40	0.2	4500	1	370
	KD3429T1	12V	150	7500	40	0.5	6500	3.8	420
	KD3429T2	24V	80	7500	40	0.2	6500	1.2	320
140	KD3429P1	12V	200	9500	80	1	8000	3.8	330
	KD3429P2	24V	100	9500	40	0.3	8000	2	350
	KD3448S1	12V	150	5200	80	0.5	4500	3.2	830
	KD3448S2	24V	80	5200	80	0.3	4500	2	790
	KD3448T1	12V	220	7500	80	0.7	6500	5	730
	KD3448T2	24V	100	7500	80	0.4	6500	3	700
	KD3448P1	12V	300	9000	80	0.8	8000	5.5	670
	KD3448P2	24V	200	9000	80	0.5	8000	3.5	750