

KGB-BRAKE TYPE

DIMENSIONS

KGB BRAKE SERIES

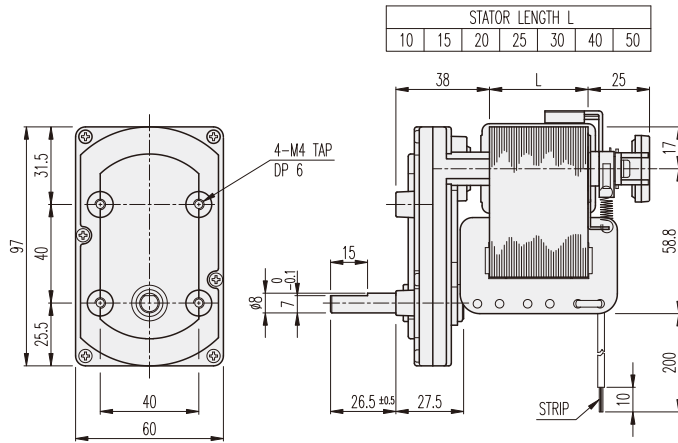
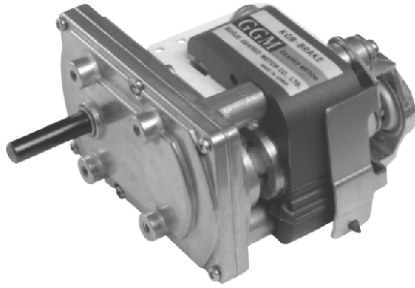

AT MAXIMUM EFFICIENCY (KGB-□□□□-KA61□□BE)

MOTOR	KA6120BE				KA6130BE				KA6140BE				KA6150BE			
	50		60		50		60		50		60		50		60	
GEAR RATIO	rpm	kgf-cm	rpm	kgf-cm	rpm	kgf-cm	rpm	kgf-cm	rpm	kgf-cm	rpm	kgf-cm	rpm	kgf-cm	rpm	kgf-cm
1/0010	240	1.2	290	1	240	2.7	290	2.5	240	4	290	3.7	240	6.4	290	5
1/0015	160	1.8	193.3	1.4	160	4.1	193.3	3.7	160	6	193.3	5.6	160	9.6	193.3	7.5
1/0021	114.3	2.5	138.1	2	114.3	5.8	138.1	5.2	114.3	8.4	138.1	7.9	114.3	13.5	138.1	10.5
1/0027	88.9	3.2	107.4	2.6	88.9	7.4	107.4	6.7	88.9	10.8	107.4	10.1	88.9	17.3	107.4	13.5
1/0036	66.7	4.3	80.6	3.5	66.7	9.9	80.6	8.9	66.7	14.4	80.6	13.5	66.7	20	80.6	18
1/0043	55.8	5.1	67.4	4.1	55.8	11.8	67.4	10.6	55.8	17.2	67.4	16.1	55.8	20	67.4	20
1/0047	51.1	5.6	61.7	4.5	51.1	12.9	61.7	11.6	51.1	20	61.7	17.6	51.1	20	61.7	20
1/0055	43.6	6.5	52.7	5.3	43.6	15.1	52.7	13.6	43.6	20	52.7	20	43.6	20	52.7	20
1/0060	40	7.1	48.3	5.8	40	16.4	48.3	14.8	40	20	48.3	20	40	20	48.3	20
1/0075	32	8.9	38.7	7.2	32	20	38.7	18.5	32	20	38.7	20	32	20	38.7	20
1/0086	27.9	10.2	33.7	8.3	27.9	20	33.7	20	27.9	20	33.7	20	27.9	20	33.7	20
1/0100	24	11.8	29	9.6	24	20	29	20	24	20	29	20	24	20	29	20
1/0115	20.9	13.6	25.2	11.1	20.9	20	25.2	20	20.9	20	25.2	20	20.9	20	25.2	20
1/0126	19	14.9	23	12.1	19	20	23	20	19	20	23	20	19	20	23	20
1/0131	18.3	15.5	22.1	12.6	18.3	20	22.1	20	18.3	20	22.1	20	18.3	20	22.1	20
1/0154	15.6	18.2	18.8	14.8	15.6	20	18.8	20	15.6	20	18.8	20	15.6	20	18.8	20
1/0172	14	20	16.9	16.6	14	20	16.9	20	14	20	16.9	20	14	20	16.9	20
1/0215	11.2	20	13.5	20	11.2	20	13.5	20	11.2	20	13.5	20	11.2	20	13.5	20
1/0300	8	20	9.7	20	8	20	9.7	20	8	20	9.7	20	8	20	9.7	20
1/0380	6.3	20	7.6	20	6.3	20	7.6	20	6.3	20	7.6	20	6.3	20	7.6	20
1/0408	5.9	20	7.1	20	5.9	20	7.1	20	5.9	20	7.1	20	5.9	20	7.1	20
1/0532	4.5	20	5.5	20	4.5	20	5.5	20	4.5	20	5.5	20	4.5	20	5.5	20
1/0673	3.6	20	4.3	20	3.6	20	4.3	20	3.6	20	4.3	20	3.6	20	4.3	20
1/0825	2.9	20	3.5	20	2.9	20	3.5	20	2.9	20	3.5	20	2.9	20	3.5	20

* 위의 DATA는 BRAKE TYPE SHADED POLE MOTOR를 적용한 경우입니다.
 * □ 색상의 감속비는 MOTOR와 출력축의 회전방향에 같습니다.
 * 표준은 F-TYPE 입니다.