

KMF-TYPE

DIMENSIONS

KMF SERIES

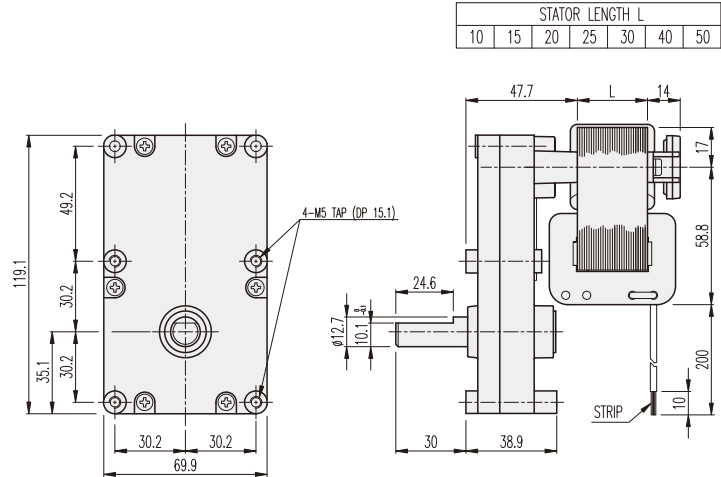
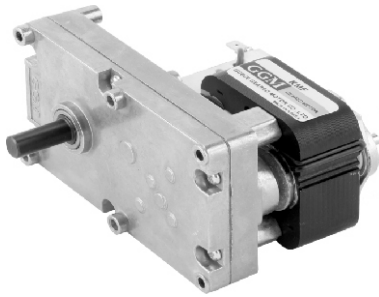

AT MAXIMUM EFFICIENCY (KMF-□□□□-KA61□□AE)

MOTOR	KA6120AE				KA6130AE				KA6140AE				KA6150AE			
	50		60		50		60		50		60		50		60	
GEAR RATIO	rpm	kgf-cm	rpm	kgf-cm	rpm	kgf-cm	rpm	kgf-cm	rpm	kgf-cm	rpm	kgf-cm	rpm	kgf-cm	rpm	kgf-cm
1/0150	16	7.1	19.3	5.7	16	13.3	19.3	9.6	16	17.4	19.3	13.2	16	22.0	19.3	17.7
1/0330	7.3	15.6	8.8	12.5	7.3	29.2	8.8	21.0	7.3	30	8.8	29.0	7.3	30	8.8	30
1/0500	4.8	23.6	5.8	18.9	4.8	30	5.8	30	4.8	30	5.8	30	4.8	30	5.8	30
1/0550	4.4	26.0	5.3	20.8	4.4	30	5.3	30	4.4	30	5.3	30	4.4	30	5.3	30
1/0760	3.2	30	3.8	28.7	3.2	30	3.8	30	3.2	30	3.8	30	3.2	30	3.8	30
1/0850	2.8	30	3.4	30	2.8	30	3.4	30	2.8	30	3.4	30	2.8	30	3.4	30
1/0940	2.6	30	3.1	30	2.6	30	3.1	30	2.6	30	3.1	30	2.6	30	3.1	30
1/1410	1.7	30	2.1	30	1.7	30	2.1	30	1.7	30	2.1	30	1.7	30	2.1	30
1/1740	1.4	30	1.7	30	1.4	30	1.7	30	1.4	30	1.7	30	1.4	30	1.7	30
1/2250	1.1	30	1.3	30	1.1	30	1.3	30	1.1	30	1.3	30	1.1	30	1.3	30
1/2360	1.0	30	1.2	30	1.0	30	1.2	30	1.0	30	1.2	30	1.0	30	1.2	30
1/2610	0.9	30	1.1	30	0.9	30	1.1	30	0.9	30	1.1	30	0.9	30	1.1	30
1/3140	0.8	30	0.9	30	0.8	30	0.9	30	0.8	30	0.9	30	0.8	30	0.9	30

* 위의 DATA는 GENERAL TYPE SHADED POLE MOTOR를 적용한 경우입니다.
 * 감속비전체 MOTOR와 출력축의 회전방향이 반대입니다.
 * 표준은 F-TYPE 입니다.