

## REVERSIBLE MOTOR

25W

□80mm

LEAD WIRE TYPE  
TERMINAL BOX TYPE

K8RS25N□



K8RS25N□-T, T5



### SPECIFICATIONS

25W 30분 정격, 4극

Model	Voltage (V)	Frequency (Hz)	Current (A)	Start T. (N·m/kgf·cm)	Rated T. (N·m/kgf·cm)	Speed (rpm)	Condenser (μF)
K8R□25NJ(-T, -T5)	100	50	0,65	0,15/1,5	0,195/1,95	1250	10
		60	0,74		0,165/1,65	1500	
K8R□25NU(-T, -T5)	110	60	0,51	0,13/1,3	0,165/1,65	1500	6
	115		0,54				
K8R□25NL(-T, -T5)	200	50	0,33	0,16/1,6	0,195/1,95	1250	2,5
		60	0,37		0,16/1,6	1550	
K8R□25NC(-T, -T5)	220	50	0,29	0,15/1,5	0,195/1,95	1250	2
		60	0,34		0,165/1,65	1500	
	230	50	0,35	0,165/1,65	0,195/1,95	1250	
		60	0,34		0,165/1,65	1500	
K8R□25ND(-T, -T5)	240	50	0,32	0,15/1,5	0,19/1,9	1300	1,5

\* □ : SHAFT 형상 ( S : STRAIGHT, G : PINION ) \* 기종 명 끝에 NU 품번은 UL규격 인증 제품입니다. UL FILE NO. E204632

### RATED TORQUE OF GEARHEAD

#### ● 50Hz

단위 = 상단 : N·m / 하단 : kgf·cm

Model	Speed(rpm)	500	416	300	250	200	166	150	120	100	83	75	60	50	41	37	30	25	20	16	15	12,5	10	8,3	7,5	6	
Motor/ Gearhead	Ratio	3	3,6	5	6	7,5	9	10	12,5	15	18	20	25	30	36	40	50	60	75	90	100	120	150	180	200	250	
K8R□25N□(-T, -T5) K8G□B(C)		0,46	0,55	0,77	0,92	1,15	1,39	1,54	1,92	2,31	2,77	2,77	3,46	4,16	4,99	5,54	6,23	7,48	8	8	8	8	8	8	8	8	8
		4,6	5,5	7,7	9,2	11,5	13,9	15,4	19,2	23,1	27,7	27,7	34,6	41,6	49,9	55,4	62,3	74,8	80	80	80	80	80	80	80	80	80

#### ● 60Hz

단위 = 상단 : N·m / 하단 : kgf·cm

Model	Speed(rpm)	600	500	360	300	240	200	180	144	120	100	90	72	60	50	45	36	30	24	20	18	15	12	10	9	7,2	
Motor/ Gearhead	Ratio	3	3,6	5	6	7,5	9	10	12,5	15	18	20	25	30	36	40	50	60	75	90	100	120	150	180	200	250	
K8R□25N□(-T, -T5) K8G□B(C)		0,39	0,47	0,65	0,78	0,97	1,17	1,30	1,62	1,94	2,33	2,33	2,92	3,50	4,20	4,67	5,25	6,30	7,87	8	8	8	8	8	8	8	8
		3,9	4,7	6,5	7,8	9,7	11,7	13,0	16,2	19,4	23,3	23,3	29,2	35,0	42,0	46,7	52,5	63,0	78,7	80	80	80	80	80	80	80	80

- \* GEARHEAD-DECIMAL GEARHEAD는 별매입니다.
- \* GEARHEAD의 품명중 □에는 감속비가 들어갑니다.
- \* ■ 색이 MOTOR와 같은 방향, 그 외에는 반대 방향입니다.
- \* 표의 감속비보다 더 감속하고자 할 경우는 GEARHEAD와 MOTOR 사이에 감속비 10의 DECIMAL GEARHEAD를 설치할 수 있습니다. 이 경우의 허용 TORQUE는 8 N·m / 80 kgf·cm 입니다. 단, 1/20 ~ 1/40의 GEARHEAD를 설치한 경우는 6 N·m / 60 kgf·cm 입니다.
- \* 회전수는 MOTOR의 동기 회전수 (50 Hz : 1500 rpm, 60 Hz : 1800 rpm)를 기준으로 하여 감속비로 나누어서 계산하였습니다. 실제의 회전수는 부하의 크기에 따라서 표시된 수치보다 2~20% 적습니다.

## GEARHEAD

### DIMENSIONS

K8RS25N □

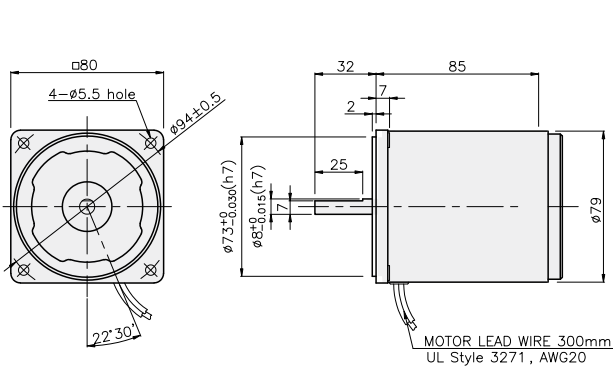

K8RS25N □-T

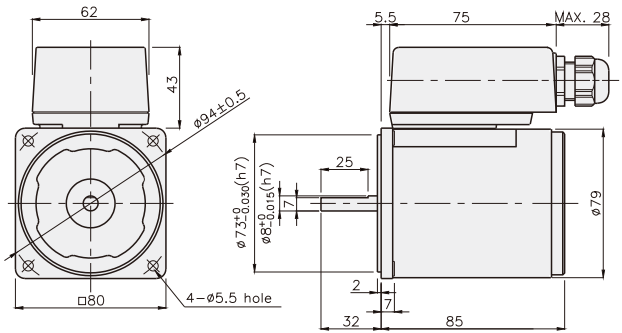

K8RS25N □-T5

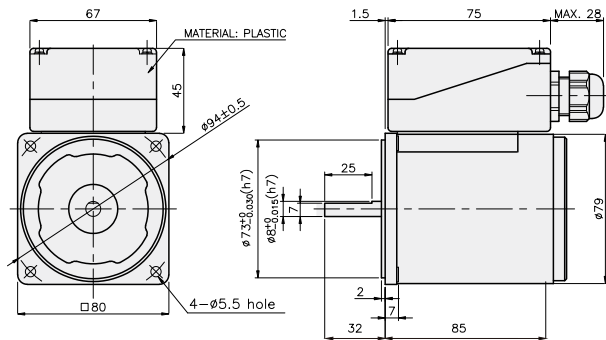

### CONNECTION DIAGRAMS

K8RS25N □

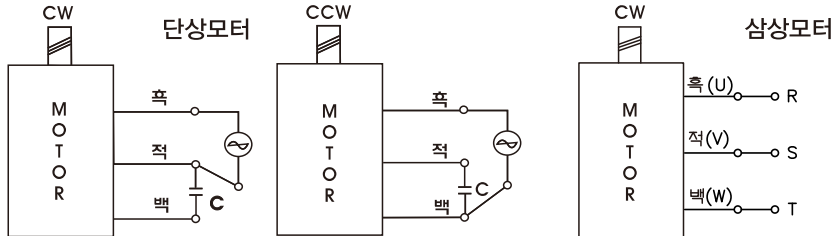

회전방향은 출력축에서 볼 경우

CCW는 U,V,W중 2선을 바꾸어 결선

K8RS25N □-T

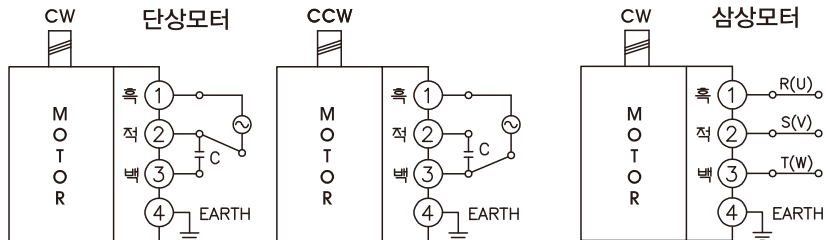

회전방향은 출력축에서 볼 경우

CCW는 U,V,W중 2선을 바꾸어 결선

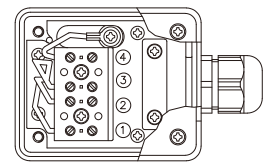

K8RS25N □-T5

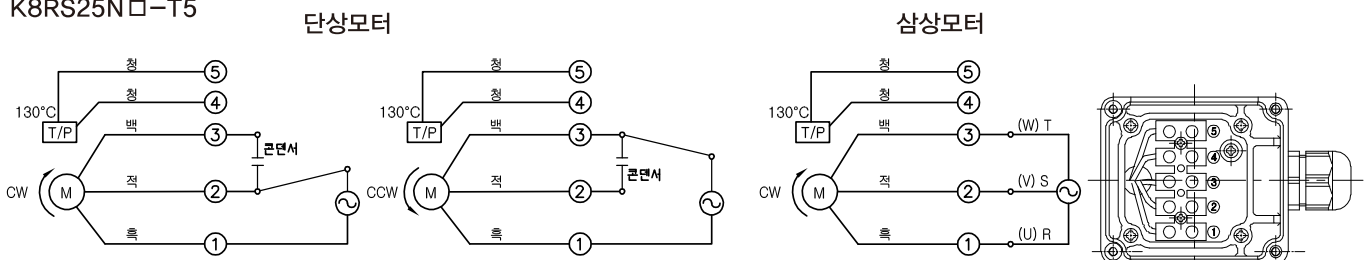

회전방향은 출력축에서 볼 경우

CCW는 U,V,W중 2선을 바꾸어 결선

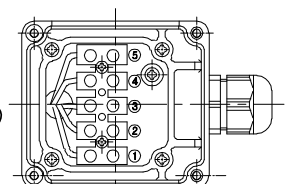

**GEARHEAD**

**DIMENSIONS**

K8G□B(C)



DECIMAL GEARHEAD  
K8G10BX

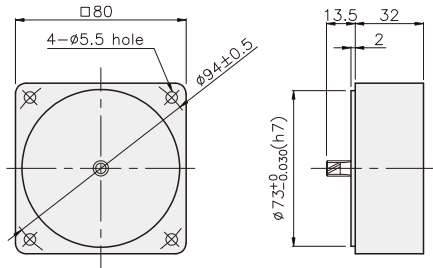

GEARHEAD  
K8G□B(C)

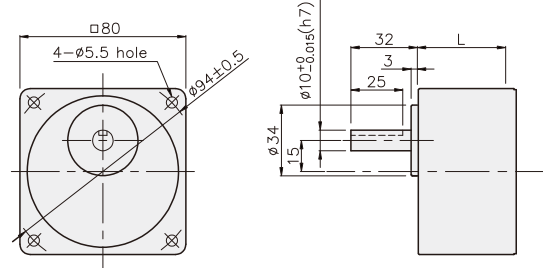

**KEY SPEC**

• KEY

• KEY GROOVE

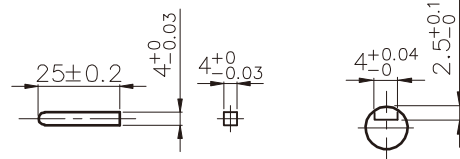

## GEARHEAD

### DIMENSIONS

K8RG25N□ + K8G□B(C)



K8RG25N□-T(-T5) + K8G□B(C)



K8RG25N□ + K8G□B(C)

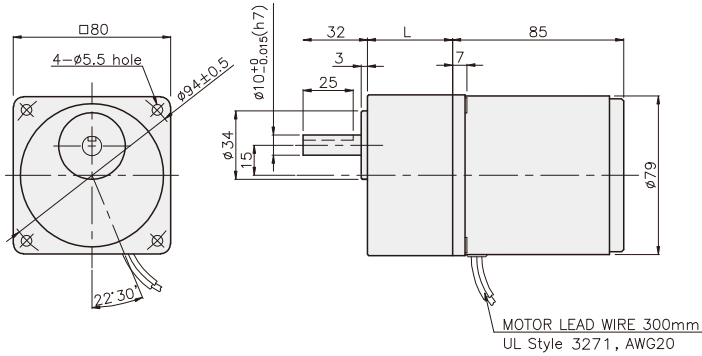

치수도표

품번	L	적용기종	취부 BOLT
01	32	K8G3~18B(C)	M5 P0.8 X 50
02	42.5	K8G20~250B(C)	M5 P0.8 X 65
03	32	K8G10BX	M5 P0.8 X 95

무게

PART	WEIGHT(kg)	
MOTOR	1.54	
DECIMAL GEARHEAD	0.46	
GEAR HEAD	K8G3~18B(C)	0.51
	K8G20~40B(C)	0.64
	K8G50~250B(C)	0.70

K8RG25N□-T + K8G□B(C)

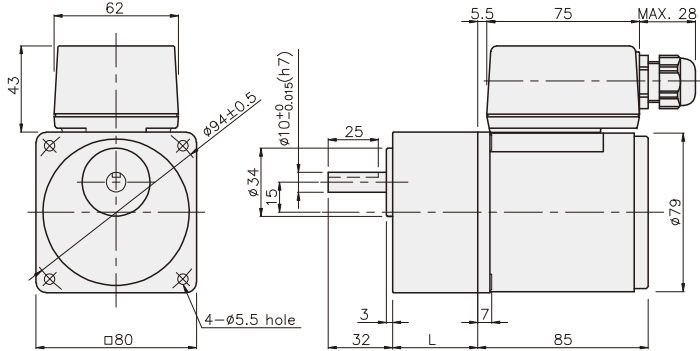

치수도표

품번	L	적용기종	취부 BOLT
01	32	K8G3~18B(C)	M5 P0.8 X 50
02	42.5	K8G20~250B(C)	M5 P0.8 X 65
03	32	K8G10BX	M5 P0.8 X 95

무게

PART	WEIGHT(kg)	
MOTOR	1.76	
DECIMAL GEARHEAD	0.46	
GEAR HEAD	K8G3~18B(C)	0.51
	K8G20~40B(C)	0.64
	K8G50~250B(C)	0.70

K8RG25N□-T5 + K8G□B(C)

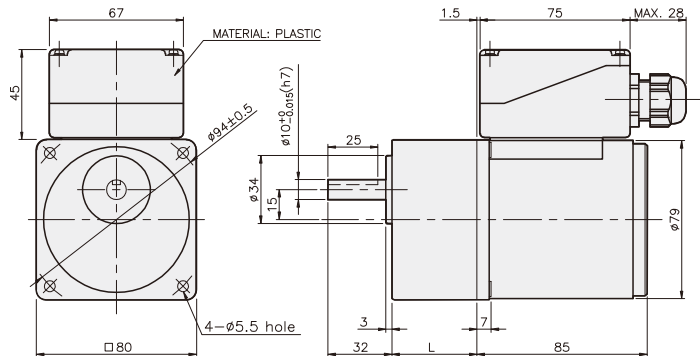

치수도표

품번	L	적용기종	취부 BOLT
01	32	K8G3~18B(C)	M5 P0.8 X 50
02	42.5	K8G20~250B(C)	M5 P0.8 X 65
03	32	K8G10BX	M5 P0.8 X 95

무게

PART	WEIGHT(kg)	
MOTOR	1.76	
DECIMAL GEARHEAD	0.46	
GEAR HEAD	K8G3~18B(C)	0.51
	K8G20~40B(C)	0.64
	K8G50~250B(C)	0.70