

REVERSIBLE MOTOR

40W

□80mm

LEAD WIRE TYPE

K8R□40F□



SPECIFICATIONS

40W 30분정격, 4극

Model	Out Put (W)	Voltage (V)	Frequency (Hz)	Current (A)	Start T. (N·m/kgf·cm)	Rated T. (N·m/kgf·cm)	Speed (rpm)	Condenser (μF)
K8R□40FC	단상	40	50	0.41	0.27	0.300	1300	3
					2.78	3.00		
			60	0.40	0.27	0.245	1600	
					2.78	2.45		
		230	50	0.44	0.31	0.300	1300	
					3.18	3.00		
			60	0.41	0.30	0.245	1600	
					3.10	2.45		

* □ : SHAFT 형상 (S : STRAIGHT, G : PINION)

DIMENSIONS & CONNECTION DIAGRAMS

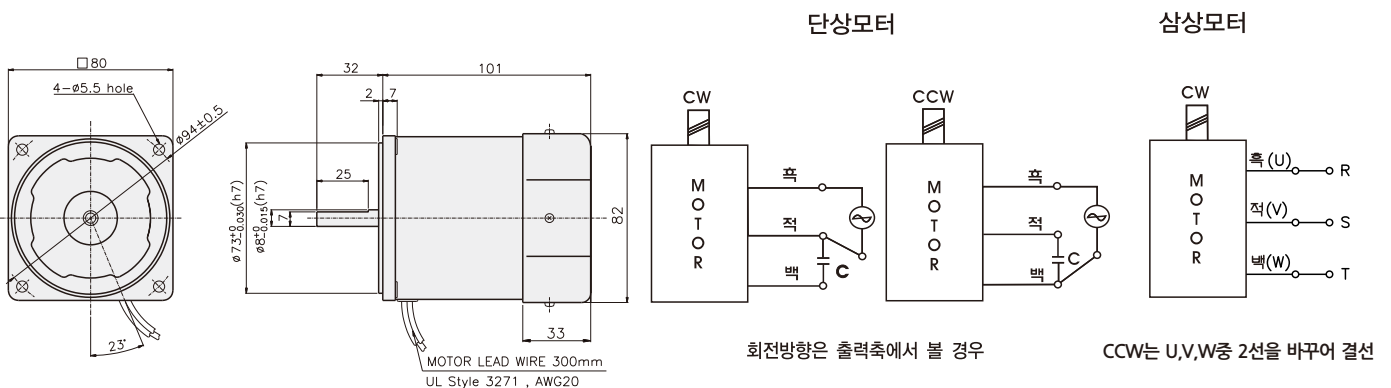

GEARHEAD

DIMENSIONS

K8G□B(C)



K8RG40F□ + K8G□B(C)



DECIMAL GEARHEAD
K8G10BX

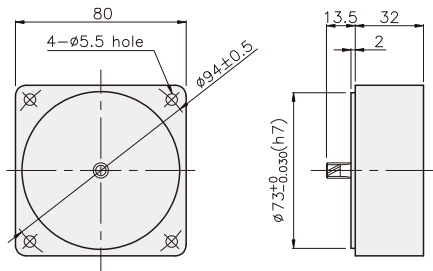

GEARHEAD
K8G□B(C)

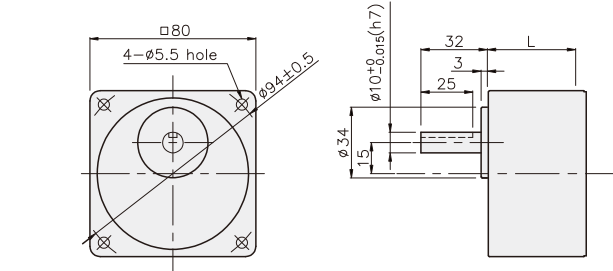

KEY SPEC

- KEY
- KEY GROOVE

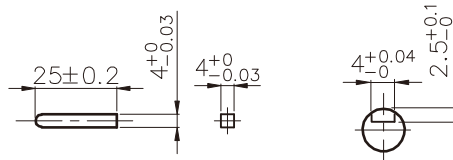

K8RG40F□ + K8G□B(C)

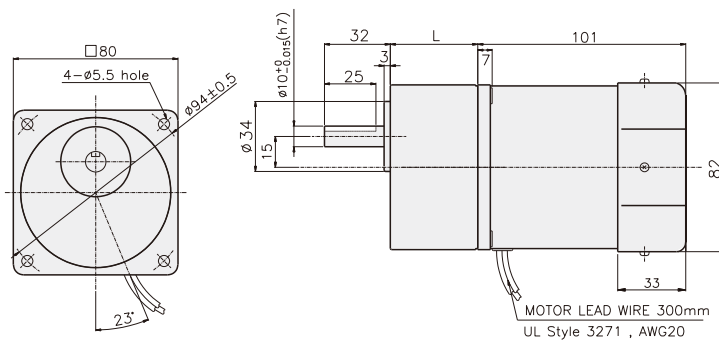

치수도표

품번	L	적용기종	취부 BOLT
01	32	K8G3~18B(C,M)	M5 P0.8 X 50
02	42.5	K8G20~250B(C,M)	M5 P0.8 X 65

무게

PART	WEIGHT(kg)	
MOTOR	1.70	
DECIMAL GEARHEAD	0.46	
GEAR HEAD	K8G3~18B(C)	0.51
	K8G20~40B(C)	0.64
	K8G50~250B(C)	0.70