

## REVERSIBLE MOTOR

### 15W

### □70mm

### LEAD WIRE TYPE TERMINAL BOX TYPE

K7RS15N□



K7RS15N□-T



### SPECIFICATIONS

15W 30분 정격, 4극

Model	Voltage (V)	Frequency (Hz)	Current (A)	Start T. (N·m/Kgf·Cm)	Rated T. (N·m/Kgf·Cm)	Speed (rpm)	Condenser (μF)
K7R□15NJ(-T)	100	50	0,46	0,115/1,15	0,12/1,2	1250	7
		60	0,48		0,1/1	1500	
K7R□15NU(-T)	110	60	0,47	0,12/1,2	0,1/1	1500	6
	115		0,49	0,125/1,25			
K7R□15NL(-T)	200	50	0,23	0,115/1,15	0,12/1,2	1250	2
		60	0,28		0,1/1	1500	
K7R□15NC(-T)	220	50	0,21	0,115/1,15	0,12/1,2	1250	1,5
		60	0,24		0,1/1	1500	
	230	50	0,25	0,125/1,25	0,12/1,2	1250	
		60	0,24	0,125/1,25	0,1/1	1500	
K7R□15ND(-T)	240	50	0,25	0,13/1,3	0,12/1,2	1250	1,5

\* □ : SHAFT 형상(S : STRAIGHT, G : PINION)

### RATED TORQUE OF GEARHEAD

#### ● 50Hz

단위 = 상단 : N·m / 하단 : Kgtcm

Model	Speed(rpm)	500	416	300	250	200	166	150	120	100	83	75	60	50	41	37	30	25	20	16	15	12,5	10	8,3	9
Motor/ Gearhead	Ratio	3	3,6	5	6	7,5	9	10	12,5	15	18	20	25	30	36	40	50	60	75	90	100	120	150	180	200
K7R□15N□(-T) K7G□B(C)		0,29	0,35	0,49	0,58	0,73	0,87	0,97	1,22	1,46	1,75	1,75	2,19	2,62	3,15	3,50	3,94	4,72	5	5	5	5	5	5	5
		2,9	3,5	4,9	5,8	7,3	8,7	9,7	12,2	14,6	17,5	17,5	21,9	26,2	31,5	35,0	39,4	47,2	50	50	50	50	50	50	50

#### ● 60Hz

단위 = 상단 : N·m / 하단 : Kgtcm

Model	Speed(rpm)	600	500	360	300	240	200	180	144	120	100	90	72	60	50	45	36	30	24	20	18	15	12	10	9
Motor/ Gearhead	Ratio	3	3,6	5	6	7,5	9	10	12,5	15	18	20	25	30	36	40	50	60	75	90	100	120	150	180	200
K7R□15N□(-T) K7G□B(C)		0,24	0,29	0,41	0,49	0,61	0,73	0,81	1,01	1,22	1,46	1,46	1,82	2,19	2,26	2,92	3,28	3,94	4,92	5	5	5	5	5	5
		2,4	2,9	4,1	4,9	6,1	7,3	8,1	10,1	12,2	14,6	14,6	18,2	21,9	26,2	29,2	32,8	39,4	49,2	50	50	50	50	50	50

- \* GEARHEAD · DECIMAL GEARHEAD는 별매입니다.
- \* GEARHEAD의 품명중 □에는 감속비가 들어갑니다.
- \* ■ 색이 MOTOR와 같은 방향, 그 외에는 반대 방향입니다.
- \* 표의 감속비보다 더 감속하고자 할 경우는 GEARHEAD와 MOTOR 사이에 감속비 10의 DECIMAL GEARHEAD를 설치할 수 있습니다. 이 경우의 허용 TORQUE는 5N·m/50kgfcm 입니다.
- \* 회전수는 MOTOR의 동기 회전수(50Hz:1500rpm, 60Hz:1800rpm)를 기준으로 하여 감속비로 나누어서 계산하였습니다. 실제의 회전수는 부하의 크기에 따라서 표시된 수치보다 2~20% 적습니다.

## GEARHEADS

### CONNECTION DIAGRAMS

K7RS15N□

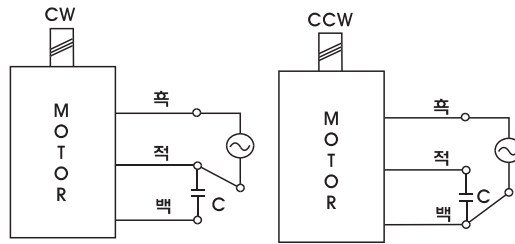

회전방향은 출력축에서 볼 경우

K7RS15N□-T

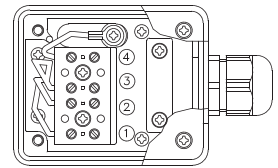
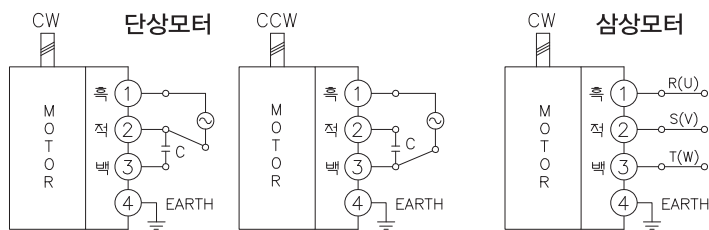

회전방향은 출력축에서 볼 경우

### DIMENSIONS

K7G□B(C)



DECIMAL GEARHEAD  
K7G10BX

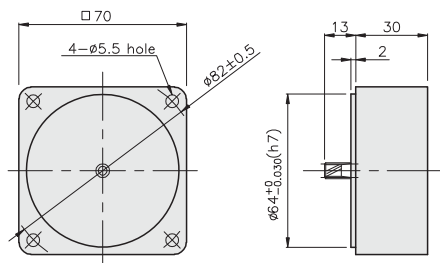

GEARHEAD  
K7G□B(C)

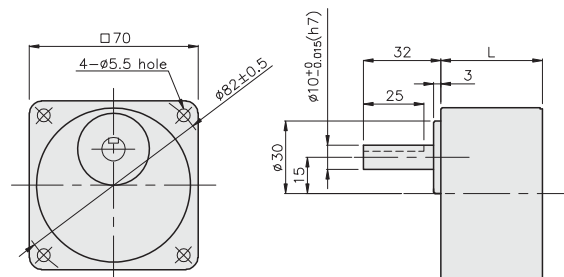

• KEY

• KEY GROOVE

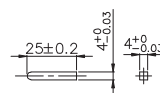

## GEARHEADS

### DIMENSIONS

K7RG15N□ + K7G□B(C)



K7RG15N□-T + K7G□B(C)



#### 치수도표

품번	L	적용기종	취부 BOLT
01	32	K7G3~18B(C)	M5 P0,8 X 50
02	42	K7G20~200B(C)	M5 P0,8 X 65
03	30	K7G10BX	M5 P0,8 X 90

#### 무게

PART	WEIGHT(kg)	
MOTOR	1,11	
DECIMAL GEAR HEAD	0,32	
GEAR HEAD	K7G3~18B(C)	0,38
	K7G20~40B(C)	0,46
	K7G50~200B(C)	0,51

K7RG15N□ + K7G□B(C)

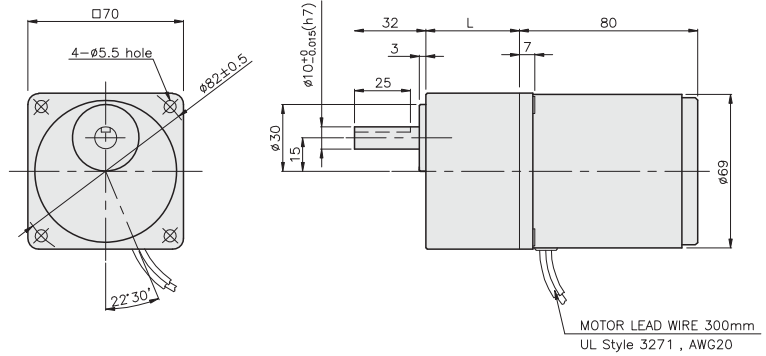

#### 치수도표

품번	L	적용기종	취부 BOLT
01	32	K7G3~18B(C)	M5 P0,8 X 50
02	42	K7G20~200B(C)	M5 P0,8 X 65
03	30	K7G10BX	M5 P0,8 X 90

#### 무게

PART	WEIGHT(kg)	
MOTOR	1,10	
DECIMAL GEAR HEAD	0,32	
GEAR HEAD	K7G3~18B(C)	0,38
	K7G20~40B(C)	0,46
	K7G50~200B(C)	0,51

K7RG15N□-T + K7G□B(C)

