

INDUCTION MOTOR

25W

□80mm LEAD WIRE TYPE
TERMINAL BOX TYPE

K8IS25N□



K8IS25N□-T, T5



SPECIFICATIONS

25W 연속정격, 4극

Model		Voltage (V)	Frequency (Hz)	Current (A)	Start T. (N·m/kgf·cm)	Rated T. (N·m/kgf·cm)	Speed (rpm)	Condenser (μF)
K8I□25NJ(-T, -T5)	단상	100	50	0.59	0.11/1.1	0.195/1.95	1250	7
K8I□25NU(-T, -T5)			60	0.54		0.16/1.6	1550	
K8I□25NL(-T, -T5)		200	50	0.26	0.115/1.15	0.195/1.95	1250	1.8
			60	0.28		0.16/1.6	1550	
K8I□25NC(-T, -T5)		220	50	0.28	0.11/1.1	0.195/1.95	1250	1.5
			60	0.25		0.16/1.6	1550	
K8I□25ND(-T, -T5)		230	50	0.29	0.12/1.2	0.195/1.95	1250	1.5
			60	0.26		0.16/1.6	1550	
K8I□25ND(-T, -T5)		240	50	0.3	0.11/1.1	0.195/1.95	1250	1.2
K8I□25NT(-T, -T5)		삼상	200	50	0.27	0.5/5	0.19/1.9	1300
K8I□25NH(-T, -T5)	60			0.24	0.4/4	0.16/1.6	1550	
K8I□25NH(-T, -T5)	220		50	0.28	0.6/6	0.185/1.85	1350	-
			60	0.24	0.48/4.8	0.155/1.55	1600	
K8I□25NM(-T, -T5)	230		50	0.29	0.65/6.5	0.185/1.85	1350	-
			60	0.25	0.52/5.2	0.155/1.55	1600	
K8I□25NV(-T, -T5)	380		50	0.17	0.6/6	0.19/1.9	1300	-
			60	0.14	0.48/4.8	0.155/1.55	1600	
K8I□25NQ(-T, -T5)	400		50	0.17	0.73/7.3	0.19/1.9	1300	-
			60	0.15	0.6/6	0.155/1.55	1600	
K8I□25NZ(-T, -T5)	415	50	0.13	0.55/5.5	0.19/1.9	1300	-	
		60	0.11	0.4/4	0.155/1.55	1600		
K8I□25NZ(-T, -T5)	440	50	0.14	0.63/6.3	0.19/1.9	1300	-	
		60	0.12	0.5/5	0.155/1.55	1600		

* □ : SHAFT 형상 (S : STRAIGHT, G : PINION)

* 삼상 380V이상 사양의 MOTOR는 INVERTER와의 조합에서는 사용 할 수 없습니다. MOTOR 권선의 절연이 열화되어 파손될 가능성이 있습니다.

RATED TORQUE OF GEARHEAD

● 50Hz

단위 = 상단 : N·m / 하단 : kgf·cm

Model Motor/ Gearhead	Speed(rpm)	500	416	300	250	200	166	150	120	100	83	75	60	50	41	37	30	25	20	16	15	12.5	10	8.3	7.5	6
	Ratio	3	3.6	5	6	7.5	9	10	12.5	15	18	20	25	30	36	40	50	60	75	90	100	120	150	180	200	250
K8I□25N□(-T, -T5) K8G□B(C)	0.45	0.54	0.75	0.90	1.12	1.35	1.50	1.87	2.25	2.70	2.70	3.37	4.05	4.86	5.39	6.07	7.28	8	8	8	8	8	8	8	8	8
	4.5	5.4	7.5	9.0	11.2	13.5	15.0	18.7	22.5	27.0	27.0	33.7	40.5	48.6	53.9	60.7	72.8	80	80	80	80	80	80	80	80	80

● 60Hz

단위 = 상단 : N·m / 하단 : kgf·cm

Model Motor/ Gearhead	Speed(rpm)	600	500	360	300	240	200	180	144	120	100	90	72	60	50	45	36	30	24	20	18	15	12	10	9	7.2
	Ratio	3	3.6	5	6	7.5	9	10	12.5	15	18	20	25	30	36	40	50	60	75	90	100	120	150	180	200	250
K8I□25N□(-T, -T5) K8G□B(C)	0.38	0.45	0.63	0.75	0.94	1.13	1.26	1.57	1.88	2.26	2.26	2.82	3.39	4.07	4.52	5.08	6.10	7.63	8	8	8	8	8	8	8	8
	3.8	4.5	6.3	7.5	9.4	11.3	12.6	15.7	18.8	22.6	22.6	28.2	33.9	40.7	45.2	50.8	61.0	76.3	80	80	80	80	80	80	80	80

* GEARHEAD-DECIMAL GEARHEAD는 별매입니다.

* GEARHEAD의 품명중 □에는 감속비가 들어갑니다.

* □ 색이 MOTOR와 같은 방향, 그 외에는 반대 방향입니다.

* 표의 감속비보다 더 감속하고자 할 경우는 GEARHEAD와 MOTOR 사이에 감속비 10의 DECIMAL GEARHEAD를 설치할 수 있습니다.

이 경우의 허용 TORQUE는 8 N·m / 80 kgf·cm 입니다. 단, 1/20 ~ 1/40의 GEARHEAD를 설치한 경우는 6 N·m / 60 kgf·cm 입니다.

* 회전수는 MOTOR의 동기 회전수 (50 Hz : 1500 rpm, 60 Hz : 1800 rpm)를 기준으로 하여 감속비로 나누어서 계산하였습니다.

실제의 회전수는 부하의 크기에 따라서 표시된 수치보다 2~20% 적습니다.

DIMENSIONS

K8IS25N□

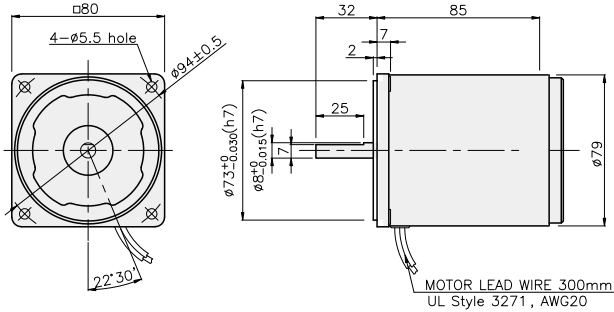

K8IS25N□-T

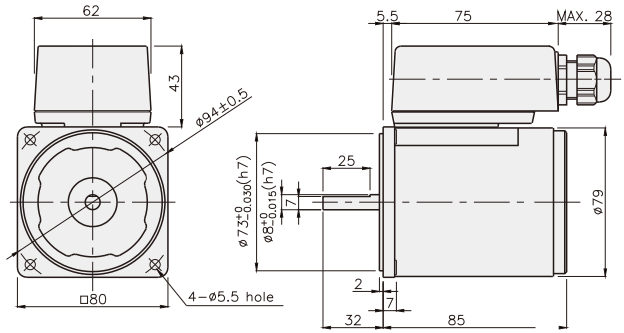

K8IS25N□-T5

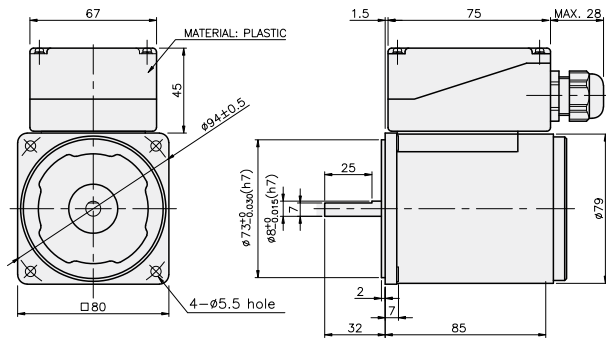

CONNECTION DIAGRAMS

K8IS25N□

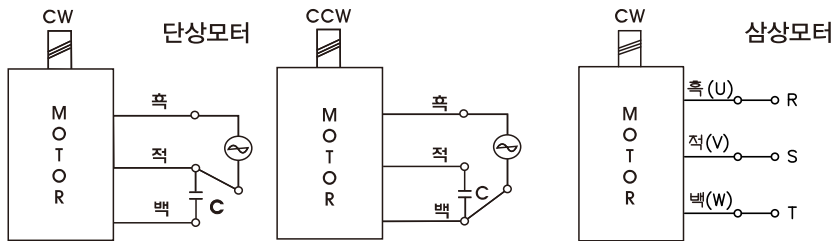

회전방향은 출력축에서 볼 경우

CCW는 U,V,W중 2선을 바꾸어 결선

K8IS25N□-T

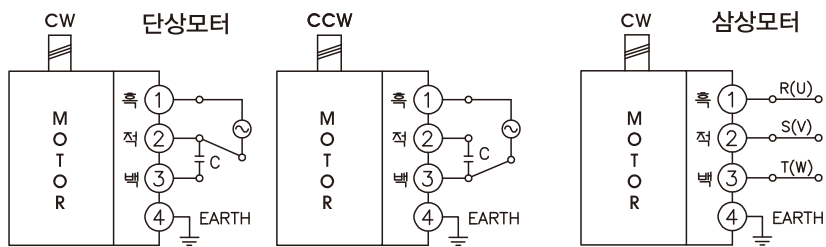

회전방향은 출력축에서 볼 경우

CCW는 U,V,W중 2선을 바꾸어 결선

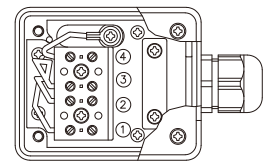

K8IS25N□-T5

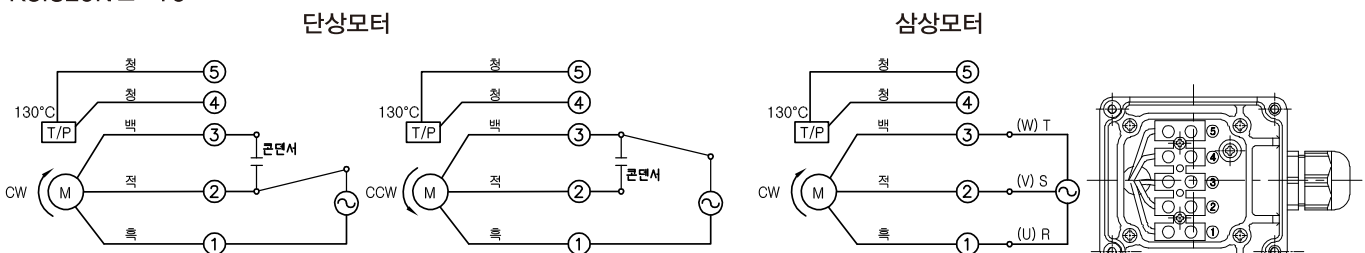

회전방향은 출력축에서 볼 경우

CCW는 U,V,W중 2선을 바꾸어 결선

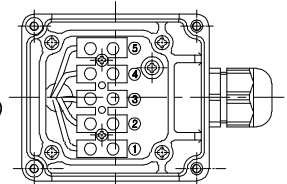

GEARHEAD

DIMENSIONS

K8G□B(C)



DECIMAL GEARHEAD
K8G10BX

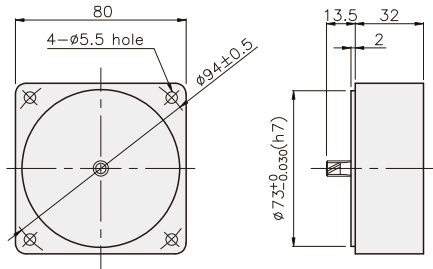

GEARHEAD
K8G□B(C)

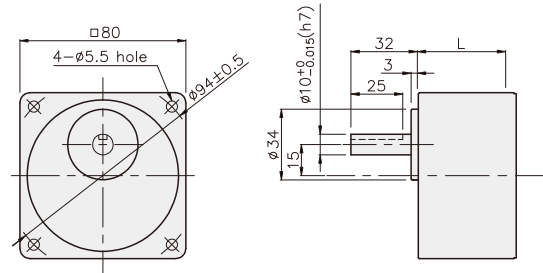

KEY SPEC

- KEY
- KEY GROOVE

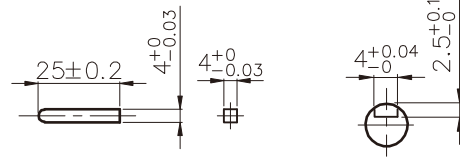

GEARHEAD

DIMENSIONS

K8IG25N□ + K8G□B(C)



K8IG25N□-T(-T5) + K8G□B(C)



INDUCTION MOTOR

K8IG25N□ + K8G□B(C)

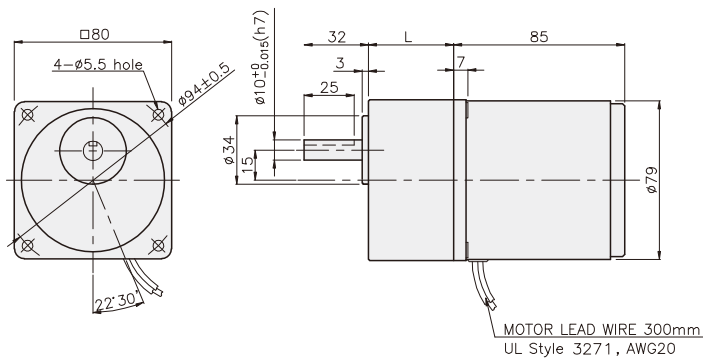

치수도표

품번	L	적용기종	취부 BOLT
01	32	K8G3~18B(C)	M5 P0,8 X 50
02	42,5	K8G20~250B(C)	M5 P0,8 X 65
03	32	K8G10BX	M5 P0,8 X 95

무게

PART		WEIGHT(kg)
MOTOR		1,58
DECIMAL GEARHEAD		0,46
GEAR HEAD	K8G3~18B(C)	0,51
	K8G20~40B(C)	0,64
	K8G50~250B(C)	0,70

K8IG25N□-T + K8G□B(C)

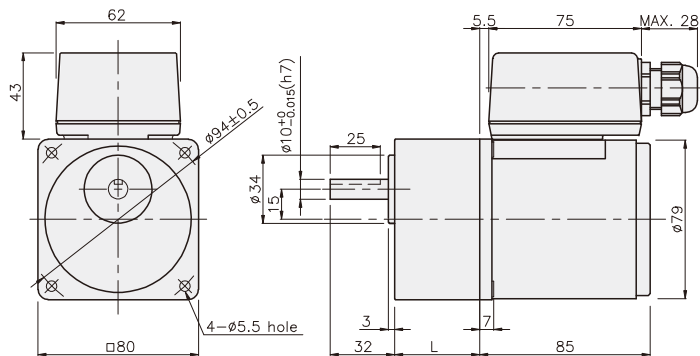

치수도표

품번	L	적용기종	취부 BOLT
01	32	K8G3~18B(C)	M5 P0,8 X 50
02	42,5	K8G20~250B(C)	M5 P0,8 X 65
03	32	K8G10BX	M5 P0,8 X 95

무게

PART		WEIGHT(kg)
MOTOR		1,76
DECIMAL GEARHEAD		0,46
GEAR HEAD	K8G3~18B(C)	0,51
	K8G20~40B(C)	0,64
	K8G50~250B(C)	0,70

K8IG25N□-T5 + K8G□B(C)

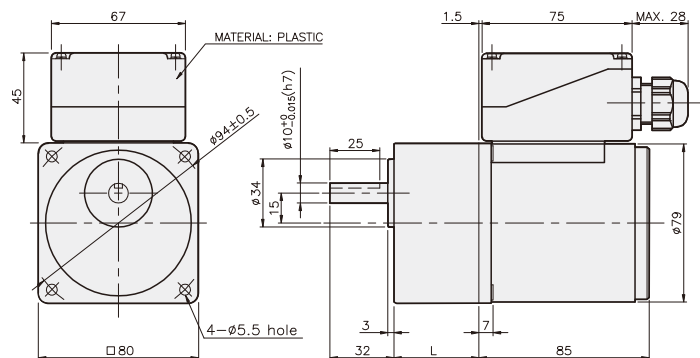

치수도표

품번	L	적용기종	취부 BOLT
01	32	K8G3~18B(C)	M5 P0,8 X 50
02	42,5	K8G20~250B(C)	M5 P0,8 X 65
03	32	K8G10BX	M5 P0,8 X 95

무게

PART		WEIGHT(kg)
MOTOR		1,76
DECIMAL GEARHEAD		0,46
GEAR HEAD	K8G3~18B(C)	0,51
	K8G20~40B(C)	0,64
	K8G50~250B(C)	0,70