

REVERSIBLE MOTOR

25W

□ 80mm

LEAD WIRE TYPE TERMINAL BOX TYPE

K8RS25N□



K8RS25N□-T, T5



SPECIFICATIONS

25W 30분 정격, 4극

Model	Voltage (V)	Frequency (Hz)	Current (A)	Start T. (N*m/Kgf* Cm)	Rated T. (N*m/Kgf* Cm)	Speed (rpm)	Condenser (μF)
K8R□25NJ(-T, -T5)	100	50	0,65	0,15/1,5	0,195/1,95	1250	10
		60	0,74		0,165/1,65	1500	
K8R□25NU(-T, -T5)	110	60	0,51	0,13/1,3	0,165/1,65	1500	6
	115		0,54				
K8R□25NL(-T, -T5)	200	50	0,33	0,16/1,6	0,195/1,95	1250	2,5
		60	0,37		0,16/1,6	1550	
K8R□25NC(-T, -T5)	220	50	0,29	0,15/1,5	0,195/1,95	1250	2
		60	0,34		0,165/1,65	1500	
	230	50	0,35	0,165/1,65	0,195/1,95	1250	
		60	0,34		0,165/1,65	1500	
K8R□25ND(-T, -T5)	240	50	0,32	0,15/1,5	0,19/1,9	1300	1,5

* □ : SHAFT 형상(S : STRAIGHT, G : PINION)

RATED TORQUE OF GEARHEAD

● 50Hz

단위 = 상단 : N·m / 하단 : Kgtcm

Model	Speed(rpm)	500	416	300	250	200	166	150	120	100	83	75	60	50	41	37	30	25	20	16	15	12,5	10	8,3	7,5	6
Motor/Gearhead	Ratio	3	3,6	5	6	7,5	9	10	12,5	15	18	20	25	30	36	40	50	60	75	90	100	120	150	180	200	250
K8R□25N□(-T, -T5) K8G□B(C)	0,46	0,55	0,77	0,92	1,15	1,39	1,54	1,92	2,31	2,77	2,77	3,46	4,16	4,99	5,54	6,23	7,48	8	8	8	8	8	8	8	8	8
	4,6	5,5	7,7	9,2	11,5	13,9	15,4	19,2	23,1	27,7	27,7	34,6	41,6	49,9	55,4	62,3	74,8	80	80	80	80	80	80	80	80	80

● 60Hz

단위 = 상단 : N·m / 하단 : Kgtcm

Model	Speed(rpm)	600	500	300	300	240	200	180	144	120	100	90	72	60	50	45	36	30	24	20	18	15	12	10	9	7,2
Motor/Gearhead	Ratio	3	3,6	5	6	7,5	9	10	12,5	15	18	20	25	30	36	40	50	60	75	90	100	120	150	180	200	250
K8R□25N□(-T, -T5) K8G□B(C)	0,39	0,47	0,65	0,78	0,97	1,17	1,30	1,62	1,94	2,33	2,33	2,92	3,50	4,20	4,67	5,25	6,30	7,87	8	8	8	8	8	8	8	8
	3,9	4,7	6,5	7,8	9,7	11,7	13,0	16,2	19,4	23,3	23,3	29,2	35,0	42,0	46,7	52,5	63,0	78,7	80	80	80	80	80	80	80	80

- * GEARHEAD · DECIMAL GEARHEAD는 별매입니다.
- * GEARHEAD의 품명중 □에는 감속비가 들어갑니다.
- * ■ 색이 MOTOR와 같은 방향, 그 외에는 반대 방향입니다.
- * 표의 감속비보다 더 감속하고자 할 경우는 GEARHEAD와 MOTOR 사이에 감속비 10의 DECIMAL GEARHEAD를 설치할 수 있습니다. 이 경우의 허용 TORQUE는 8N·m/80kgcm 입니다. (단, 1/20 ~ 1/40의 GEARHEAD를 설치한 경우는 6N·m/60kgcm입니다.)
- * 회전수는 MOTOR의 동기 회전수(50Hz:1500rpm, 60Hz:1800rpm)를 기준으로 하여 감속비로 나누어서 계산하였습니다. 실제의 회전수는 부하의 크기에 따라서 표시된 수치보다 2~20% 적습니다.

GEARHEADS

CONNECTION DIAGRAMS

K8RS25N□

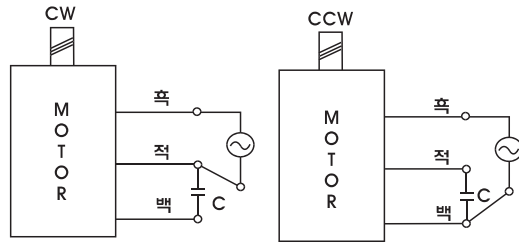

회전방향은 출력축에서 볼 경우

회전방향은 출력축에서 볼 경우

K8RS25N□-T

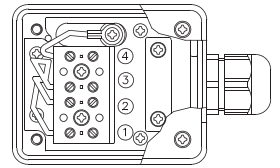
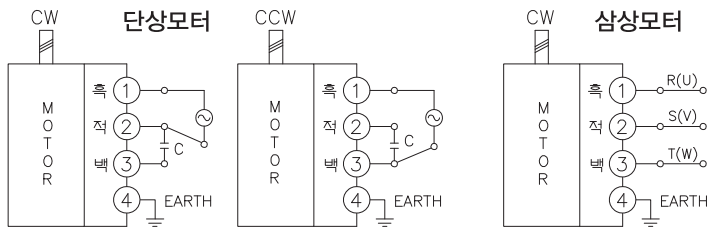

회전방향은 출력축에서 볼 경우

K8RS25N□-T5

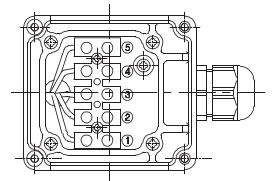
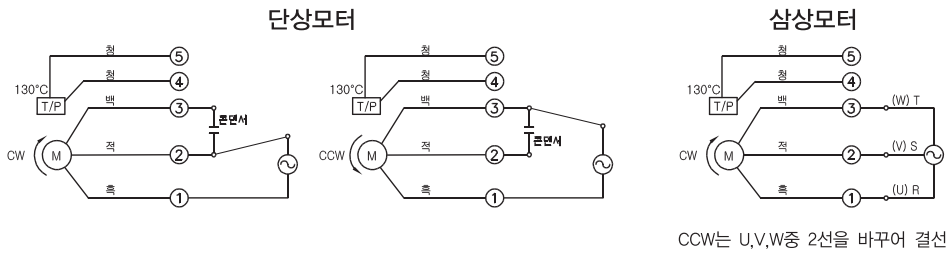

회전방향은 출력축에서 볼 경우

DIMENSIONS

K8G□B(C)



DECIMAL GEARHEAD

K8G10BX

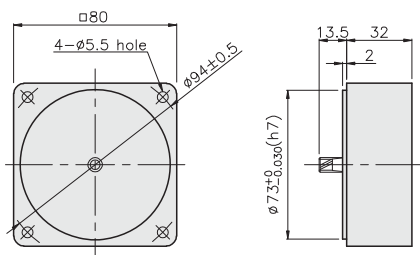

GEAR HEAD

K8G□B(C)

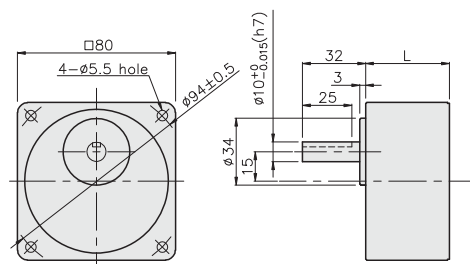

• KEY

• KEY GROOVE

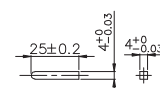

GEARHEADS

DIMENSIONS

K8RG25N□ + K8G□B(C)



K8RG25N□-T(-T5) + K8G□B(C)



K8RG25N□ + K8G□B(C)

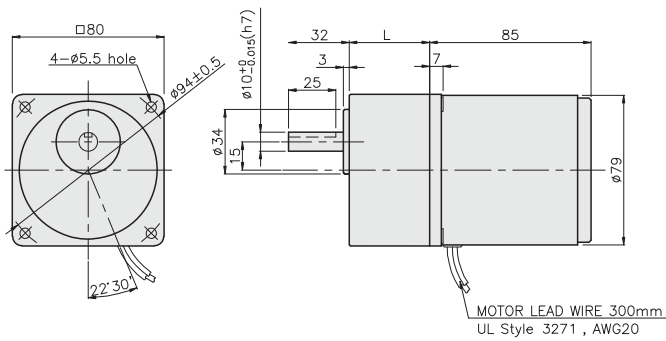

치수도표

품번	L	적용기종	취부 BOLT
01	32	K8G3~18B(C)	M5 P0.8 X 50
02	42.5	K8G20~250B(C)	M5 P0.8 X 65
03	32	K8G10BX	M5 P0.8 X 95

무게

PART	WEIGHT(kg)	
MOTOR	1.54	
DECIMAL GEAR HEAD	0.46	
GEAR HEAD	K8G3~18B(C)	0.51
	K8G20~40B(C)	0.64
	K8G50~250B(C)	0.70

K8RG25N□-T + K8G□B(C)

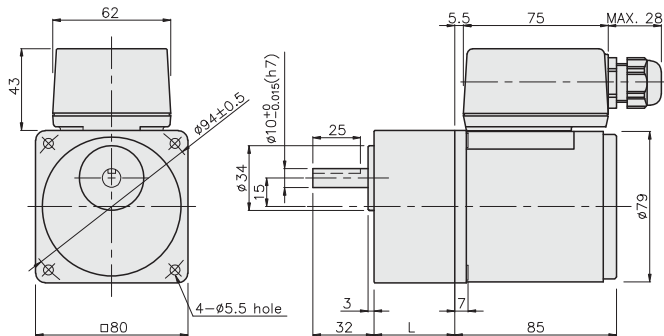

치수도표

품번	L	적용기종	취부 BOLT
01	32	K8G3~18B(C)	M5 P0.8 X 50
02	42.5	K8G20~250B(C)	M5 P0.8 X 60
03	32	K8G10BX	M5 P0.8 X 95

무게

PART	WEIGHT(kg)	
MOTOR	1.76	
DECIMAL GEAR HEAD	0.46	
GEAR HEAD	K8G3~18B(C)	0.51
	K8G20~40B(C)	0.64
	K8G50~250B(C)	0.70

K8RG25N□-T5 + K8G□B(C)

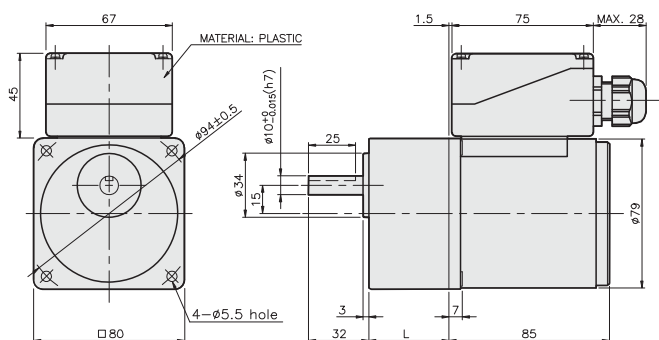

치수도표

품번	L	적용기종	취부 BOLT
01	32	K8G3~18B(C)	M5 P0.8 X 50
02	42.5	K8G20~250B(C)	M5 P0.8 X 60
03	32	K8G10BX	M5 P0.8 X 95

무게

PART	WEIGHT(kg)	
MOTOR	1.76	
DECIMAL GEAR HEAD	0.46	
GEAR HEAD	K8G3~18B(C)	0.51
	K8G20~40B(C)	0.64
	K8G50~250B(C)	0.70