

INDUCTION MOTOR

120W

□90mm

LEAD WIRE TYPE
TERMINAL BOX TYPE

INDUCTION MOTOR

K9IS120F□



K9IS120F□-T, T5



SPECIFICATIONS

120W 연속정격, 4극

Model	Voltage (V)	Frequency (Hz)	Current (A)	Start T. (N·m/kgf·cm)	Rated T. (N·m/kgf·cm)	Speed (rpm)	Condenser (μF)
K9I□120FJ-C50(-T, -T5)	100	50	2.2	0,6/6	0,9/9	1300	35
K9I□120FJ(-T, -T5)		60		0,65/6,5	0,735/7,35	1600	
K9I□120FU(-T, -T5)	110	60	2,13	0,65/6,5	0,735/7,35	1600	30
	115		2,3	0,7/7			
K9I□120FL-C50(-T, -T5)	200	50	1,07	0,65/6,5	0,9/9	1300	8,5
K9I□120FL(-T, -T5)		60	1,22		0,6/6	1550	8
K9I□120FC-C50(-T, -T5)	220	50	0,82	0,55/5,5	0,9/9	1300	6
	230		0,85	0,6/6			
K9I□120FC(-T, -T5)	220	60	1	0,6/6	0,735/7,53	1600	7
	230		1,1	0,65/6,5			
K9I□120FD-C50(-T, -T5)	240	50	0,9	0,6/6	0,9/9	1300	6

* □ : SHAFT 형상 (S : STRAIGHT, P : PINION) * 기종 명 끝에 FU 품번은 UL규격 인증 제품입니다. UL FILE NO. E204632

RATED TORQUE OF GEARHEAD

● 50Hz

단위 = 상단 : N·m / 하단 : kgf·cm

Model	Speed(rpm)	Ratio																							
		3	3.6	5	6	7.5	9	10	12.5	15	18	20	25	30	36	40	50	60	75	90	100	120	150	180	200
K9I□120F□(-T, -T5) K9P□B, BF	500	2.19	2.62	3.65	4.37	5.47	6.56	7.29	8.20	9.84	11.81	13.12	14.76	17.7	20	20	20	20	20	20	20	20	20	20	20
	250	219	262	365	437	547	656	729	820	984	1181	1312	1476	177	200	200	200	200	200	200	200	200	200	200	200

● 60Hz

단위 = 상단 : N·m / 하단 : kgf·cm

Model	Speed(rpm)	Ratio																							
		3	3.6	5	6	7.5	9	10	12.5	15	18	20	25	30	36	40	50	60	75	90	100	120	150	180	200
K9I□120F□(-T, -T5) K9P□B, BF	600	1.79	2.14	2.98	3.57	4.47	5.36	5.95	6.70	8.04	9.64	10.72	12.06	14.5	17.4	19.3	20	20	20	20	20	20	20	20	20
	300	179	214	298	357	447	536	595	670	804	964	1072	1206	145	174	193	200	200	200	200	200	200	200	200	200

- * GEARHEAD-DECIMAL GEARHEAD는 별매입니다.
- * GEARHEAD의 품명중 □에는 감속비가 들어갑니다.
- * 색이 MOTOR와 같은 방향, 그 외에는 반대 방향입니다.
- * 표의 감속비보다 더 감속하고자 할 경우는 GEARHEAD와 MOTOR 사이에 감속비 10의 DECIMAL GEARHEAD를 설치할 수 있습니다. 이 경우의 허용 TORQUE는 20 N·m / 200 kgf·cm 입니다.
- * 회전수는 MOTOR의 동기 회전수 (50 Hz : 1500 rpm, 60 Hz : 1800 rpm)를 기준으로 하여 감속비로 나누어서 계산하였습니다. 실제의 회전수는 부하의 크기에 따라서 표시된 수치보다 2~20% 적습니다.

GEARHEAD

RATED TORQUE OF GEARHEAD

● 50Hz

단위 = 상단 : N·m / 하단 : kgf·cm

Model Motor/ Gearhead	Speed(rpm)	500	416	300	250	200	166	150	120	100	83	75	60	50	41	37	30	25	20	16	15	13	10	8,3	7,5
	Ratio	3	3,6	5	6	7,5	9	10	12,5	15	18	20	25	30	36	40	50	60	75	90	100	120	150	180	200
K9I□120F□(-T, -T5) K9P□BU, BUF		2,19	2,62	3,65	4,37	5,47	6,56	7,29	8,20	9,84	11,81	13,12	14,76	17,71	21,26	23,62	29,52	30	30	30	30	30	30	30	30
		21,9	26,2	36,5	43,7	54,7	65,6	72,9	82,0	98,4	118,1	131,2	147,6	177,1	212,6	236,2	295,2	300	300	300	300	300	300	300	300

● 60Hz

단위 = 상단 : N·m / 하단 : kgf·cm

Model Motor/ Gearhead	Speed(rpm)	600	500	360	300	240	200	180	144	120	100	90	72	60	50	45	36	30	24	20	18	15	12	10	9
	Ratio	3	3,6	5	6	7,5	9	10	12,5	15	18	20	25	30	36	40	50	60	75	90	100	120	150	180	200
K9I□120F□(-T, -T5) K9P□BU, BUF		1,79	2,14	2,98	3,57	4,47	5,36	5,95	6,70	8,04	9,64	10,72	12,06	14,47	17,36	19,29	24,11	28,93	30	30	30	30	30	30	30
		17,9	21,4	29,8	35,7	44,7	53,6	59,5	67,0	80,4	96,4	107,2	120,6	144,7	173,6	192,9	241,1	289,3	300	300	300	300	300	300	300

- * GEARHEAD·DECIMAL GEARHEAD는 별매입니다.
- * GEARHEAD의 품명중 □에는 감속비가 들어갑니다.
- * □ 색이 MOTOR와 같은 방향, 그 외에는 반대 방향입니다.
- * 표의 감속비보다 더 감속하고자 할 경우는 GEARHEAD와 MOTOR 사이에 감속비 10의 DECIMAL GEARHEAD를 설치할 수 있습니다. 이 경우의 허용 TORQUE는 30 N·m / 300 kgf·cm 입니다.
- * 회전수는 MOTOR의 동기 회전수 (50 Hz : 1500 rpm, 60 Hz : 1800 rpm)를 기준으로 하여 감속비로 나누어서 계산하였습니다. 실제의 회전수는 부하의 크기에 따라서 표시된 수치보다 2~20% 적습니다.

DIMENSIONS

K9IS120F□

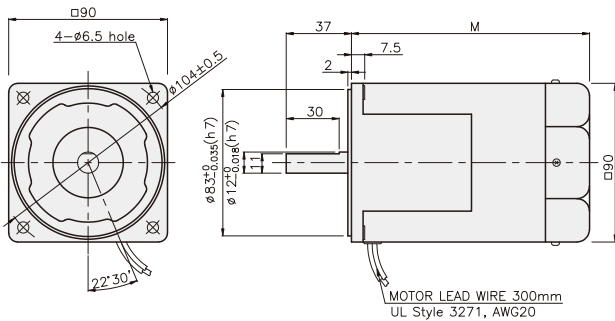

K9IS120F□-T

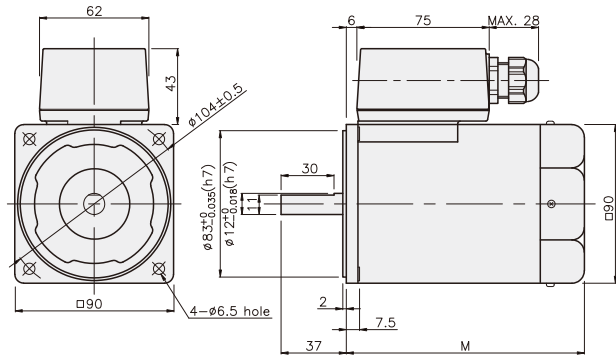

K9IS120F□-T5

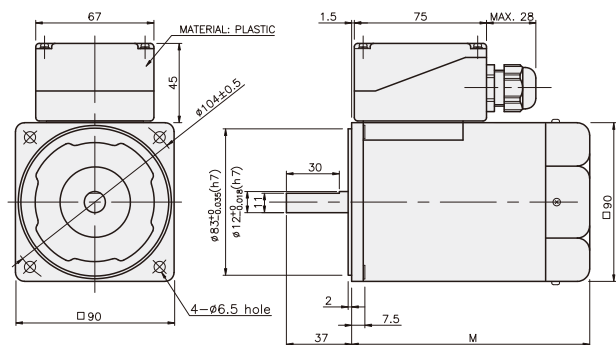

치수도표

모델	M	적용기종
K9IS120F□-C50	155	50Hz
K9IS120F□	135	60Hz

※ 50Hz 제품은 모델명에 C50이 표기됩니다.

GEARHEAD

CONNECTION DIAGRAMS

K9IS120F□

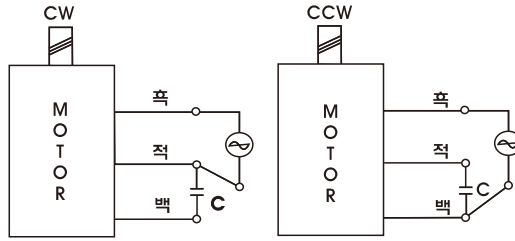

회전방향은 출력축에서 볼 경우

K9IS120F□-T

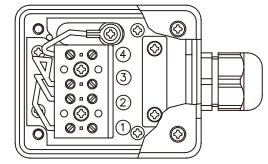
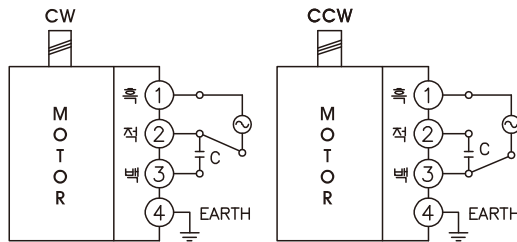

회전방향은 출력축에서 볼 경우

K9IS120F□-T5

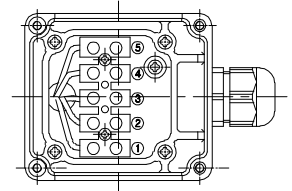
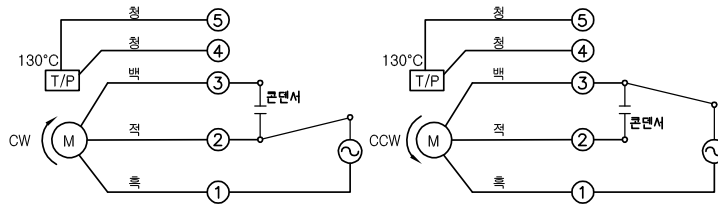

회전방향은 출력축에서 볼 경우

GEARHEAD

DIMENSIONS

K9P□B



K9P□BF, BUF



K9P□BU

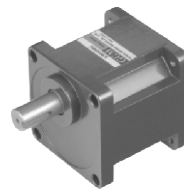

DECIMAL GEARHEAD

K9P10BX

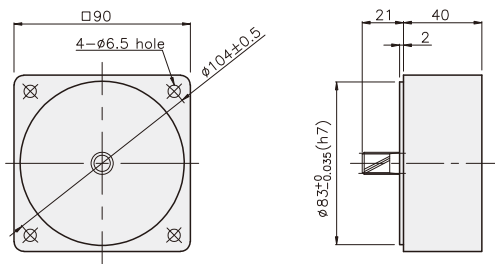

KEY SPEC

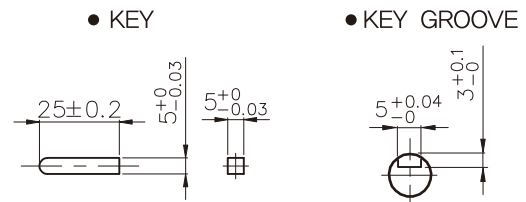

GEARHEAD

K9P□B

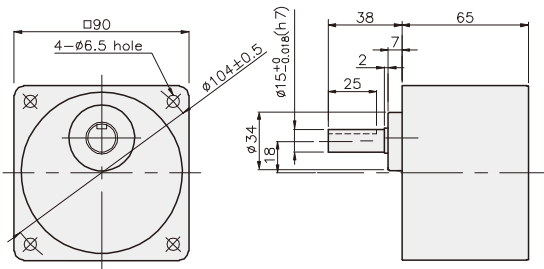

K9P□BF

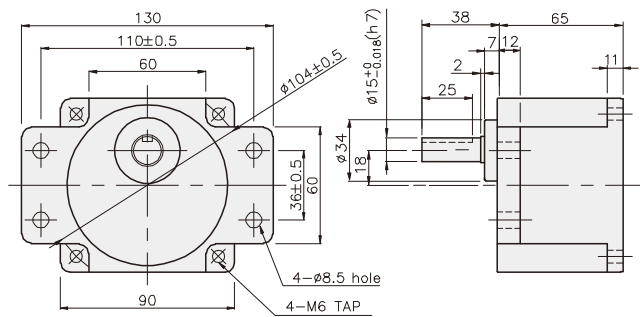

K9P□BU

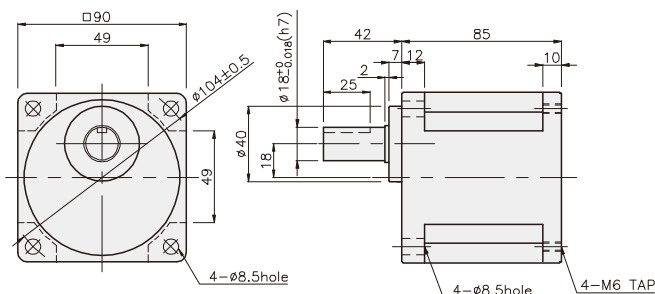

K9P□BUF

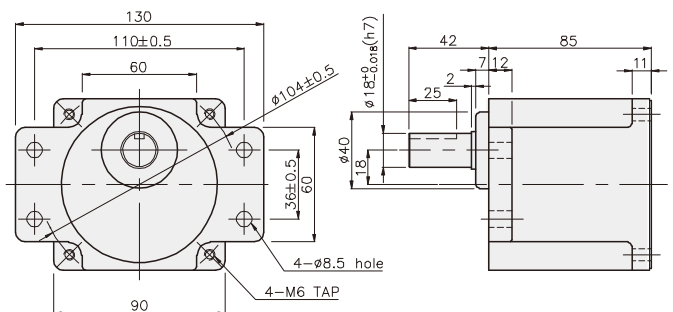

GEARHEAD

DIMENSIONS

K9IP120F□ + K9P□B



K9IP120F□ + K9P□BF, BUF



K9IP120F□ + K9P□BU

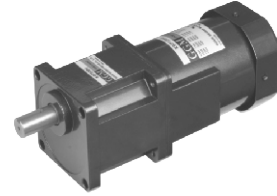

K9IP120F□ + K9P□B

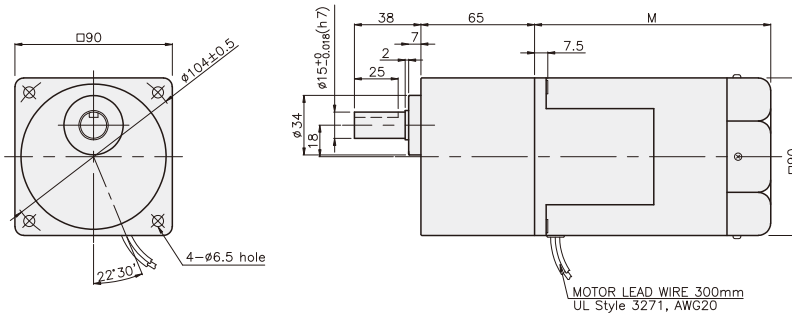

K9IP120F□ + K9P□BF

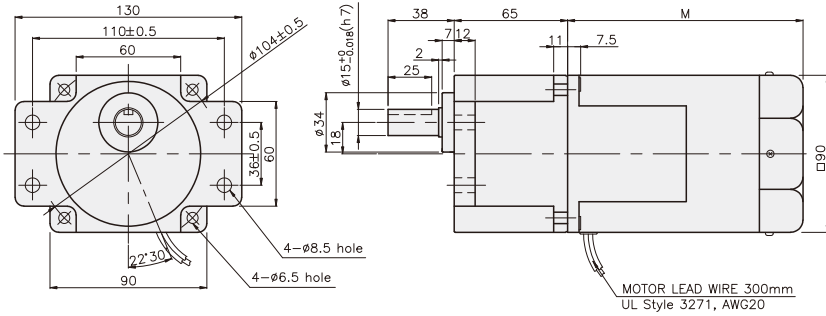

K9IP120F□ + K9P□BU

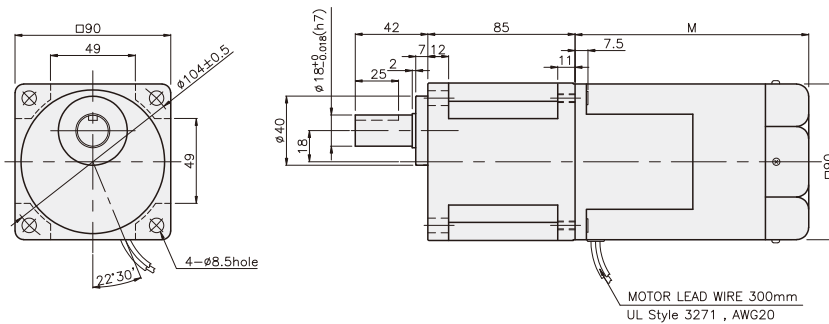

K9IP120F□ + K9P□BUF

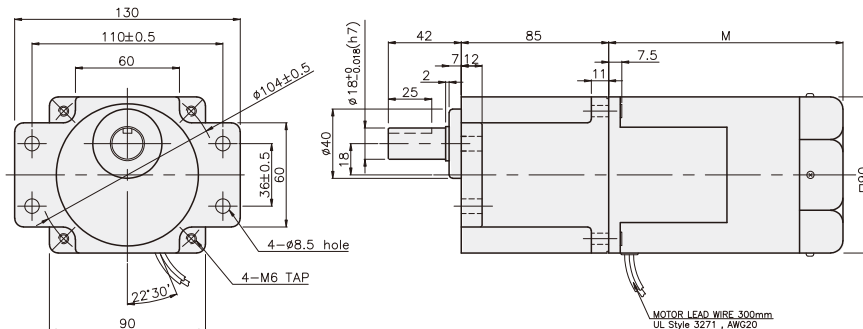

무게

PART	WEIGHT(kg)
MOTOR	3,72
DECIMAL GEARHEAD	0,62

치수도표

품번	M	적용기종
01	155	50Hz
02	135	60Hz

치수도표

품번	적용기종	취부 BOLT
01	K9P3~200B	M6 P1,0 X 95
02	K9P10BX	M6 P1,0 X 140

무게

PART	WEIGHT(kg)
K9P3~10B	1,22
K9P12,5~20B	1,32
K9P25~60B	1,42
K9P75~200B	1,45

치수도표

품번	적용기종	취부 BOLT
01	K9P3~200BF	M6 P1,0 X 20
02	K9P10BX	M6 P1,0 X 65

무게

PART	WEIGHT(kg)
K9P3~10BF	1,22
K9P12,5~20BF	1,30
K9P25~60BF	1,42
K9P75~200BF	1,44

치수도표

품번	적용기종	취부 BOLT
01	K9P3~200BU	M6 P1,0 X 20
02	K9P10BX	M6 P1,0 X 65

무게

PART	WEIGHT(kg)
K9P3~10BU	1,44
K9P12,5~20BU	1,55
K9P25~60BU	1,69
K9P75~200BU	1,74

치수도표

품번	적용기종	취부 BOLT
01	K9P3~200BUF	M6 P1,0 X 20
02	K9P10BX	M6 P1,0 X 65

무게

PART	WEIGHT(kg)
K9P3~10BUF	1,50
K9P12,5~20BUF	1,62
K9P25~60BUF	1,76
K9P75~200BUF	1,82

GEARHEAD

DIMENSIONS

K9IP120F□-T + K9P□B K9IP120F□-T + K9P□BF, BUF K9IP120F□-T + K9P□BU

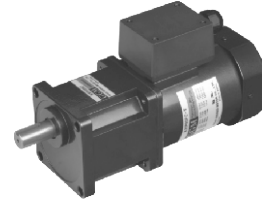
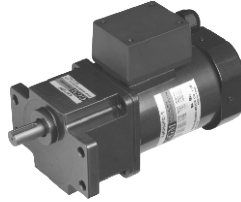

무게

PART	WEIGHT(kg)
MOTOR	3,90(50Hz)
	3,20(60Hz)
DECIMAL GEARHEAD	0,62

치수도표

품번	M	적용기종
01	155	50Hz
02	135	60Hz

치수도표

품번	적용기종	취부 BOLT
01	K9P3~200B	M6 P1,0 X 95
02	K9P10BX	M6 P1,0 X 140

K9IP120F□-T + K9P□B

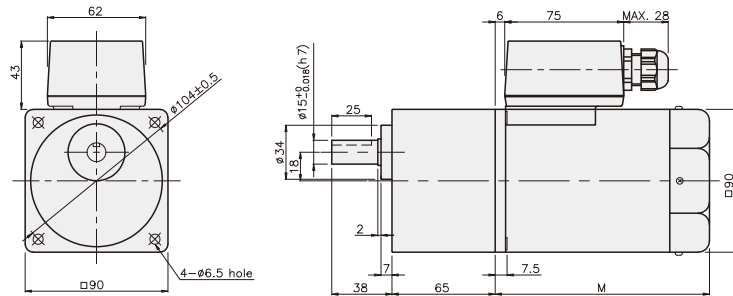

무게

PART	WEIGHT(kg)
K9P3~10B	1,22
K9P12,5~20B	1,32
K9P25~60B	1,42
K9P75~200B	1,45

치수도표

품번	적용기종	취부 BOLT
01	K9P3~200BF	M6 P1,0 X 20
02	K9P10BX	M6 P1,0 X 65

K9IP120F□-T + K9P□BF

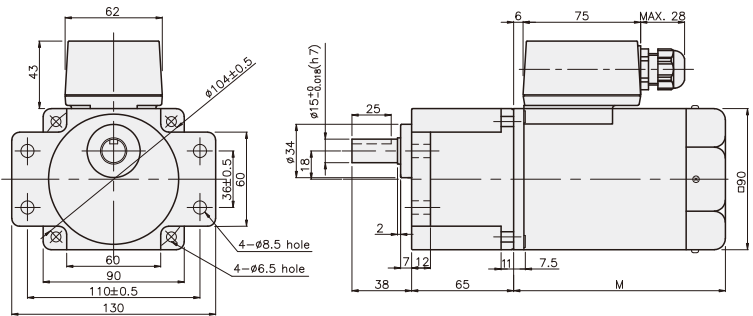

무게

PART	WEIGHT(kg)
K9P3~10BF	1,22
K9P12,5~20BF	1,30
K9P25~60BF	1,42
K9P75~200BF	1,44

치수도표

품번	적용기종	취부 BOLT
01	K9P3~200BU	M6 P1,0 X 20
02	K9P10BX	M6 P1,0 X 65

K9IP120F□-T + K9P□BU

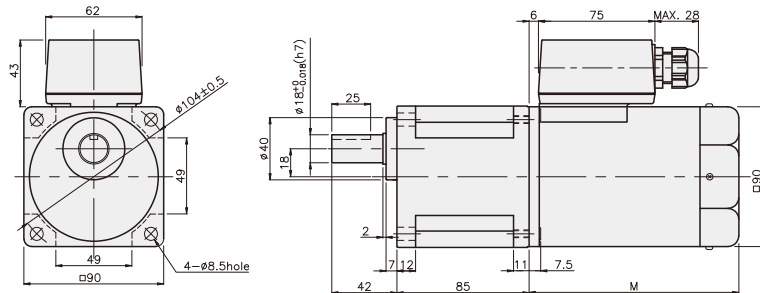

무게

PART	WEIGHT(kg)
K9P3~10BU	1,44
K9P12,5~20BU	1,55
K9P25~60BU	1,69
K9P75~200BU	1,74

치수도표

품번	적용기종	취부 BOLT
01	K9P3~200BUF	M6 P1,0 X 20
02	K9P10BX	M6 P1,0 X 65

무게

PART	WEIGHT(kg)
K9P3~10BUF	1,50
K9P12,5~20BUF	1,62
K9P25~60BUF	1,76
K9P75~200BUF	1,82

K9IP120F□-T + K9P□BUF

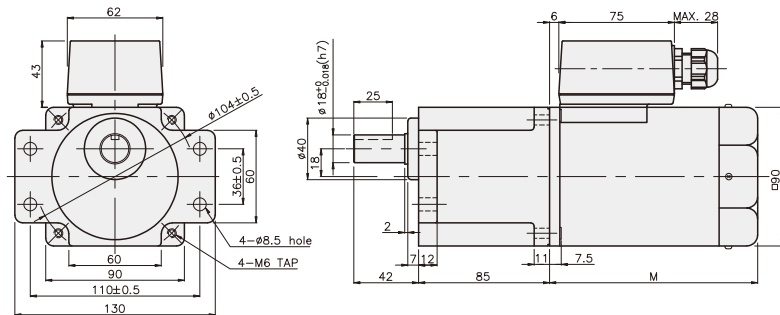

GEARHEAD

DIMENSIONS

K9IP120F□-T5 + K9P□B



K9IP120F□-T5 + K9P□BF, BUF

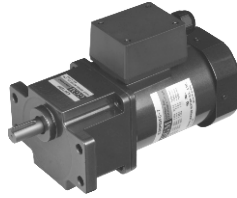

K9IP120F□-T5 + K9P□BU

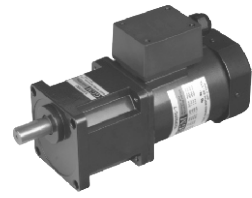

K9IP120F□-T5 + K9P□B

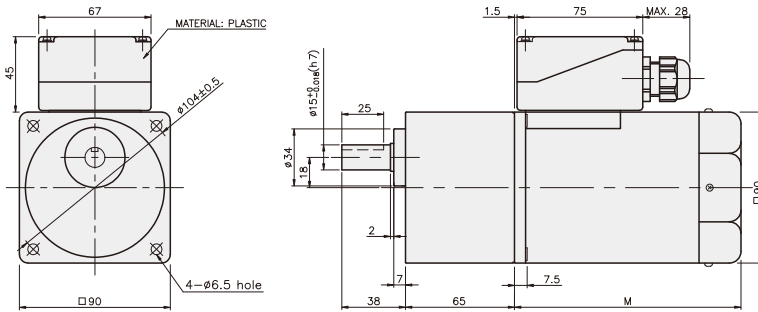

K9IP120F□-T5 + K9P□BF

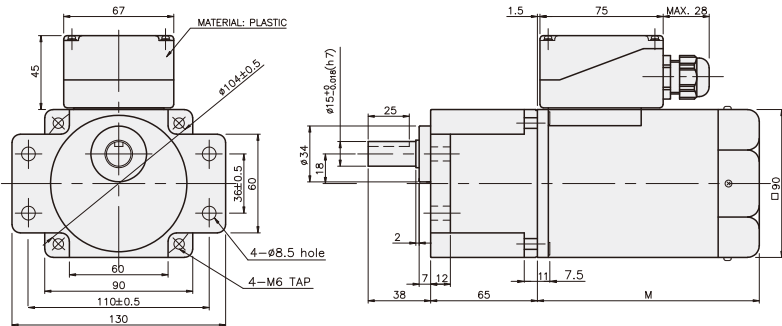

K9IP120F□-T5 + K9P□BU

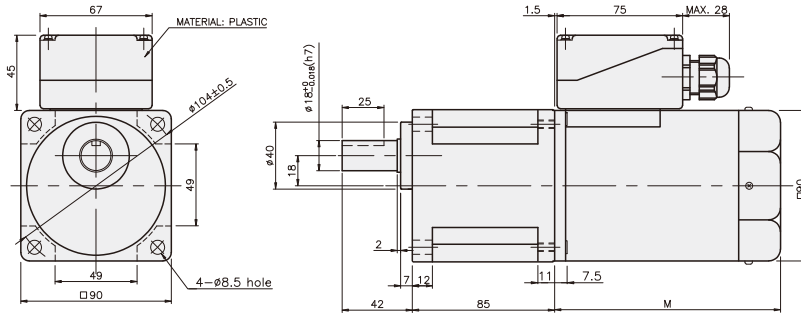

K9IP120F□-T5 + K9P□BUF

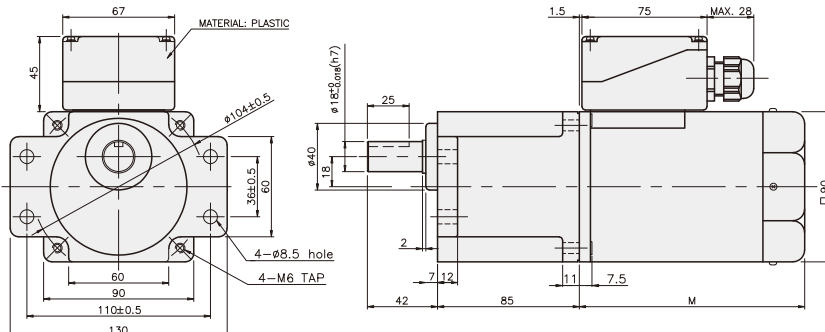

무게

PART	WEIGHT(kg)
MOTOR	3.90(50Hz)
	3.20(60Hz)
DECIMAL GEARHEAD	0.62

치수도표

품번	M	적용기종
01	155	50Hz
02	135	60Hz

치수도표

품번	적용기종	취부 BOLT
01	K9P3~200B	M6 P1.0 X 95
02	K9P10BX	M6 P1.0 X 140

무게

PART	WEIGHT(kg)
K9P3~10B	1.22
K9P12.5~20B	1.32
K9P25~60B	1.42
K9P75~200B	1.45

치수도표

품번	적용기종	취부 BOLT
01	K9P3~200BF	M6 P1.0 X 20
02	K9P10BX	M6 P1.0 X 65

무게

PART	WEIGHT(kg)
K9P3~10BF	1.22
K9P12.5~20BF	1.30
K9P25~60BF	1.42
K9P75~200BF	1.44

치수도표

품번	적용기종	취부 BOLT
01	K9P3~200BU	M6 P1.0 X 20
02	K9P10BX	M6 P1.0 X 65

무게

PART	WEIGHT(kg)
K9P3~10BU	1.44
K9P12.5~20BU	1.55
K9P25~60BU	1.69
K9P75~200BU	1.74

치수도표

품번	적용기종	취부 BOLT
01	K9P3~200BUF	M6 P1.0 X 20
02	K9P10BX	M6 P1.0 X 65

무게

PART	WEIGHT(kg)
K9P3~10BUF	1.50
K9P12.5~20BUF	1.62
K9P25~60BUF	1.76
K9P75~200BUF	1.82