

INDUCTION MOTOR

40W

□80mm LEAD WIRE TYPE

K8I□40F□



SPECIFICATIONS

40W 연속정격, 4극

Model	Out Put (W)	Voltage (V)	Frequency (Hz)	Current (A)	Start T. (N*m/Kgf*cm)	Rated T. (N*m/Kgf*cm)	Speed (rpm)	Condenser (μF)	
K8I□40FC	단상	40	220	0.45	0.23	0.315	1250	2.5	
					2.30	3.15			
			60	0.43	0.23	0.255	1550		
					2.30	2.55			
			230	50	0.50	0.27	0.315		1250
						2.70	3.15		
60	0.45	0.24	0.255	1500					
		2.40	2.55						
K8I□40FH	삼상	40	220	0.48	0.97	0.294	1300	-	
					9.70	2.90			
			60	0.35	0.71	0.245	1600		
					7.10	2.45			
			230	50	0.50	1.01	0.300		1300
						10.1	3.00		
60	0.37	0.74	0.245	1600					
		7.40	2.45						
K8I□40FM	380	50	0.26	0.76	0.300	1300	-		
				7.60	3.00				
60	0.20	0.66	0.245	1600					
		6.60	2.45						

* □ : SHAFT 형상 (S : STRAIGHT, G : PINION)

* 삼상 380V이상 사양의 MOTOR는 INVERTER와의 조합에서는 사용 할 수 없습니다. MOTOR 권선의 절연이 열화되어 파손될 가능성이 있습니다.

DIMENSIONS & CONNECTION DIAGRAMS

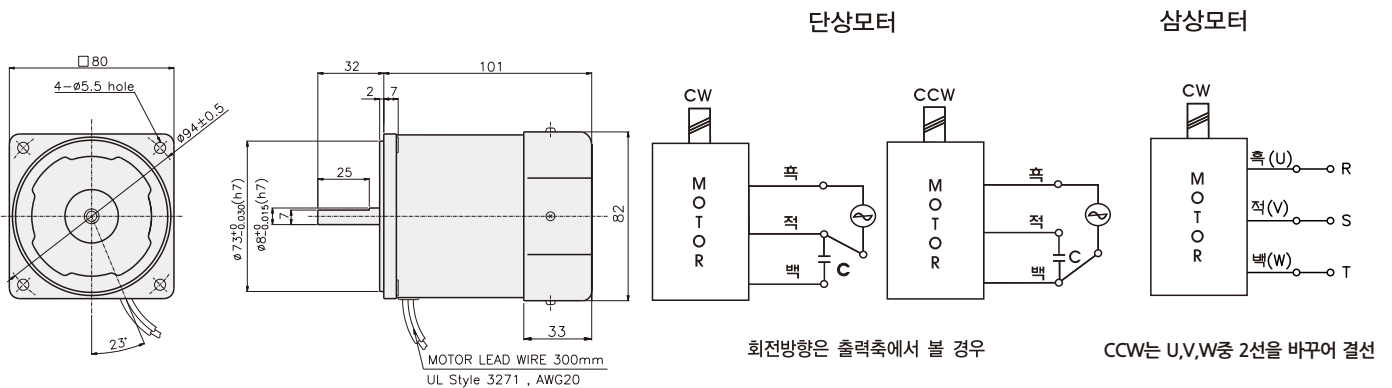

GEARHEAD

DIMENSIONS

K8G□B(C)



K8IG40F□ + K8G□B(C)



DECIMAL GEARHEAD
K8G10BX

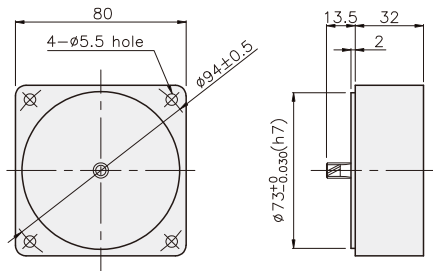

GEARHEAD
K8G□B(C)

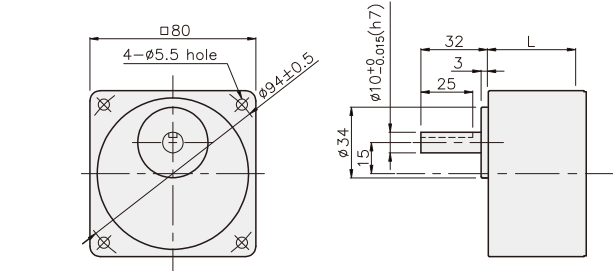

KEY SPEC

● KEY

● KEY GROOVE

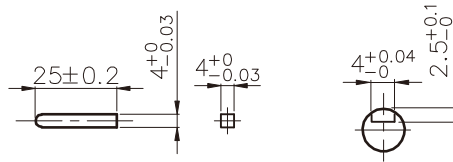

K8IP40F□ + K8G□B(C)

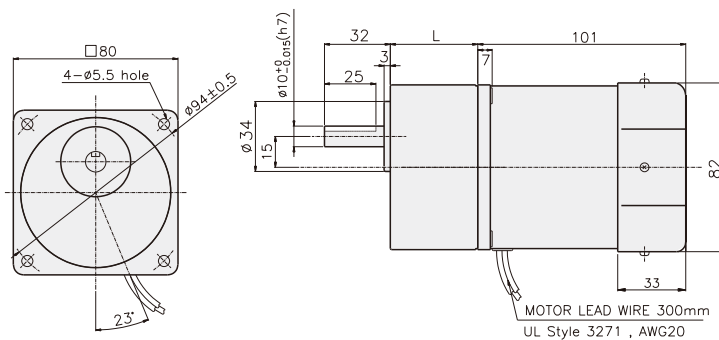

치수도표

품번	L	적용기종	취부 BOLT
01	32	K8G3~18B(C,M)	M5 P0.8 X 50
02	42.5	K8G20~250B(C,M)	M5 P0.8 X 65

무게

PART	WEIGHT(kg)	
MOTOR	1.70	
DECIMAL GEARHEAD	0.46	
GEAR HEAD	K8G3~18B(C)	0.51
	K8G20~40B(C)	0.64
	K8G50~250B(C)	0.70