

OPEN TYPE MOTOR

40W

□80mm – 83형

LEAD WIRE TYPE

DIMENSIONS

K8I□40A□

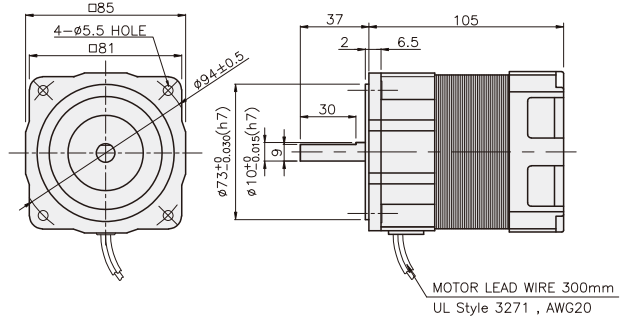

CONNECTION DIAGRAMS

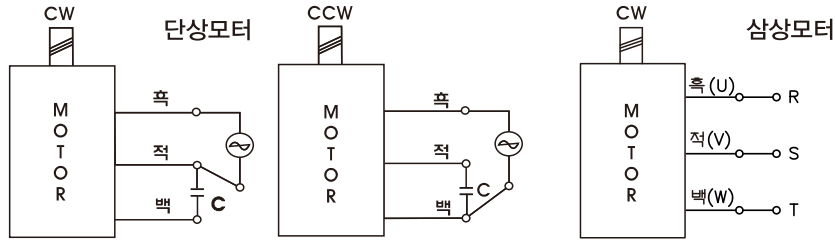

회전방향은 출력축에서 볼 경우

CCW는 U,V,W중 2선을 바꾸어 결선

SPECIFICATIONS

40W 연속정격, 4극

Model		Voltage (V)	Frequency (Hz)	Current (A)	Start T. (N·m/kgf·cm)	Rated T. (N·m/kgf·cm)	Speed (rpm)	Condenser (μF)
K8I□40AJ	단상	100	50	0.86	0.21/2.1	0.315/3.15	1250	12
			60	0.84	0.22/2.2	0.255/2.55	1550	
K8I□40AU		110	60	0.65	0.19/1.9	0.255/2.55	1550	8
				0.68	0.2/2			
K8I□40AL		200	50	0.4	0.22/2.2	0.315/3.15	1250	3
				0.41		0.255/2.55	1550	
K8I□40AC		220	50	0.38	0.24/2.4	0.315/3.15	1250	2.5
				0.37		0.255/2.55	1550	
		230	50	0.4	0.26/2.6	0.315/3.15	1250	
			60	0.38		0.255/2.55	1550	
K8I□40AD	240	50	0.37	0.2/2	0.3/3	1300	2	
K8I□40AT	200	50	0.39	1/10	0.3/3	1300	-	
			60	0.32	0.78/7.8	0.245/2.45		1600
K8I□40AH	220	50	0.33	0.95/9.5	0.29/2.9	1350	-	
			0.31	0.78/7.8	0.245/2.45	1600		
	230	50	0.41	1/10	0.29/2.9	1350		
		60	0.32	0.83/8.3	0.245/2.45	1600		
K8I□40AM	380	50	0.18	1/10	0.29/2.9	1350	-	
				60	0.78/7.8	0.245/2.45		1600
K8I□40AV	400	50	0.18	1.15/11.5	0.29/2.9	1350	-	
				60	0.19	0.88/8.8		0.245/2.45
K8I□40AQ	415	50	0.16	0.95/9.5	0.29/2.9	1350	-	
				60	0.14	0.72/7.2		0.245/2.45
K8I□40AZ	440	50	0.19	1/10	0.29/2.9	1350	-	
				60	0.16	0.79/7.9		0.245/2.45

* 모터의 사양은 INDUCTION MOTOR와 동일합니다. 적용 GEARHEAD K6G□B(C) SERIES 입니다.

* 적용 GEARHEAD 및 감속비별 출력 TORQUE 값을 알고 싶으시면 INDUCTION MOTOR의 RATED TORQUE OF GEARHEAD를 확인하십시오.

* □ : SHAFT 형상 (S : STRAIGHT, G : PINION)