

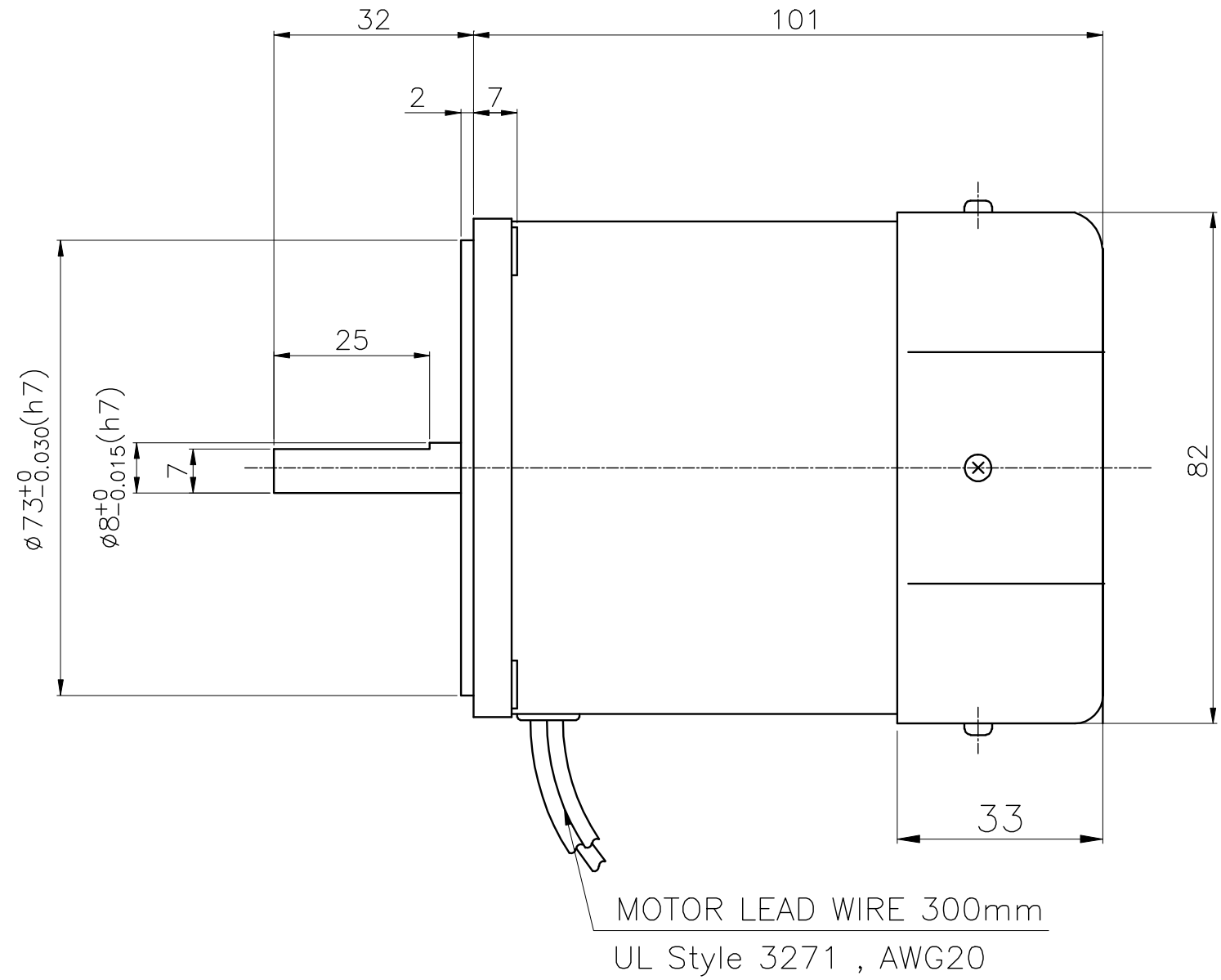

No.	REMARK	REVISION No.	SIGN

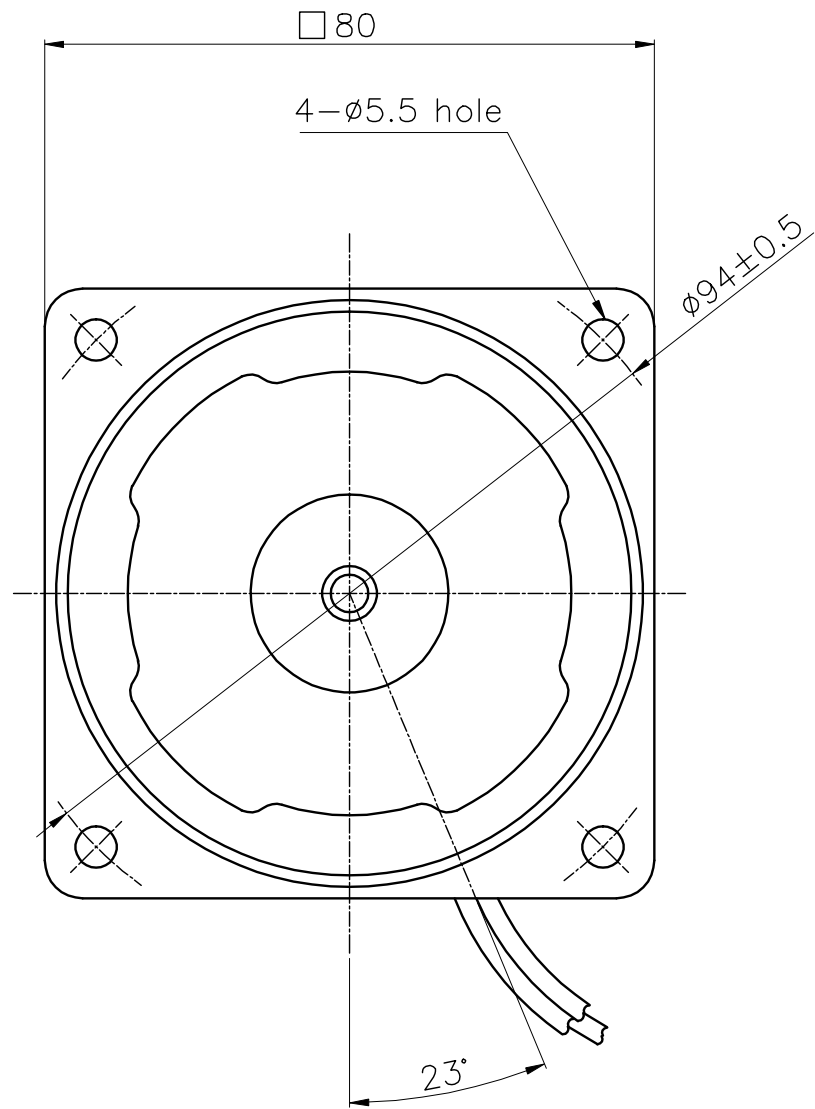
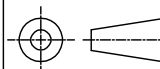

DRAW	09. 10. 13	H S. Hwang	SCALE : 1/1	PART NAME OUTLINE
DESIGNED	09. 10. 13	H S. Hwang	UNIT : mm	
CHECKED	09. 10. 13	J A. Choi		APPLICATION MODEL
APPROVED	09. 10. 13	B E. Choi		K8□S40F□
			RELATION DWG.	DWG NO. 2-OL-00157

No.	REMARK	REVISION No.	SIGN

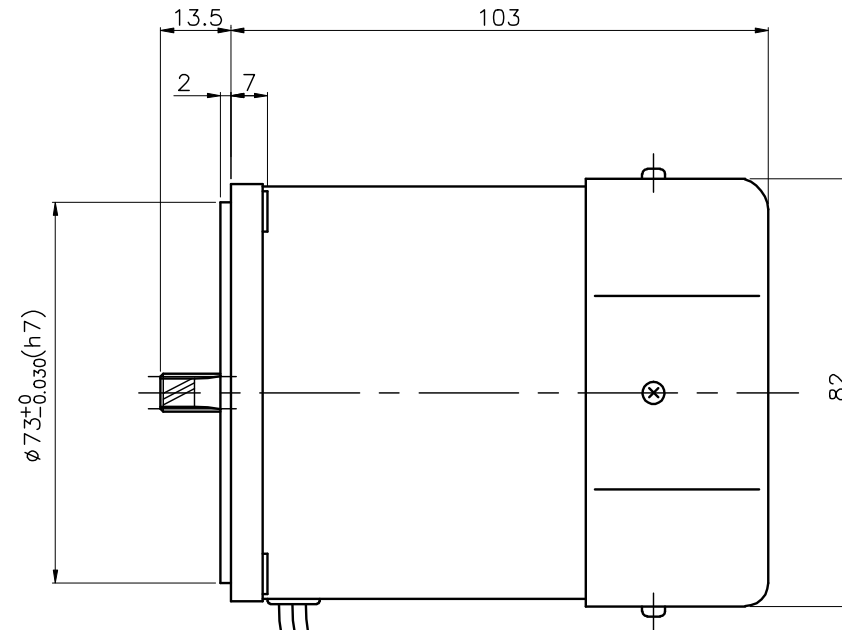
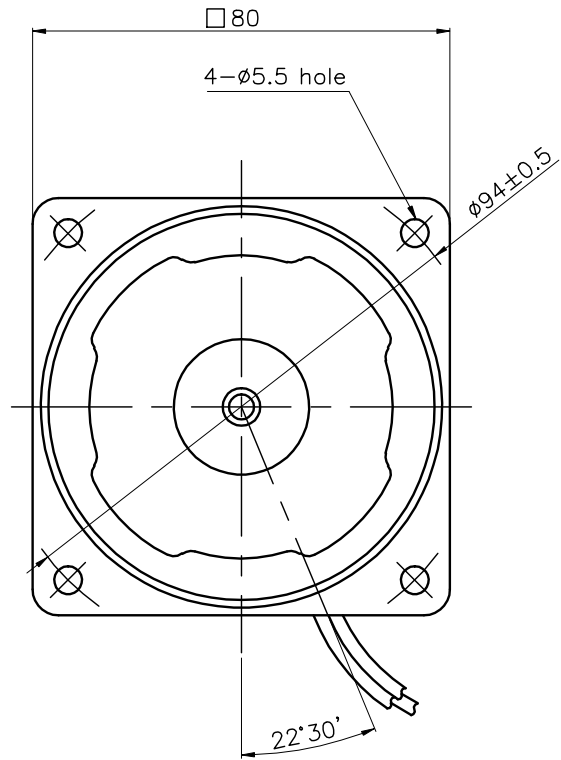

MOTOR LEAD WIRE 300mm
UL Style 3271 , AWG20

DRAW	09. 10. 13	H S. Hwang	SCALE : 1/1	PART NAME	OUTLINE
DESIGNED	09. 10. 13	H S. Hwang	UNIT : mm	APPLICATION MODEL	
CHECKED	09. 10. 13	J A. Choi		K8□G40F□	
APPROVED	09. 10. 13	B E. Choi		RELATION DWG.	DWG NO.