

KGV2-TYPE

DIMENSIONS

KGV2-3448 SERIES

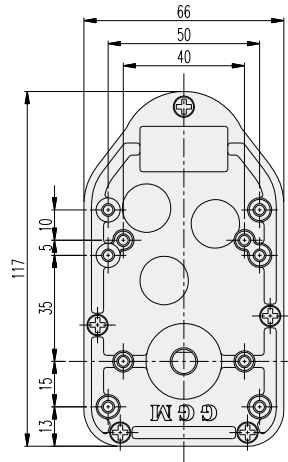
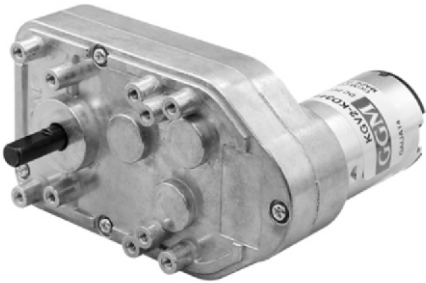

F TYPE

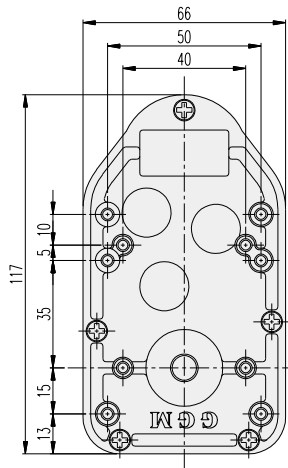
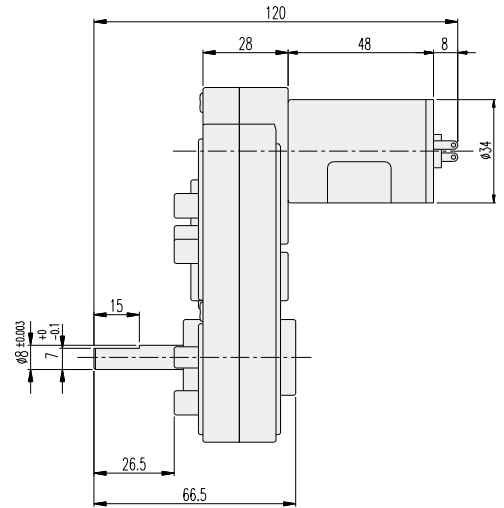

R TYPE

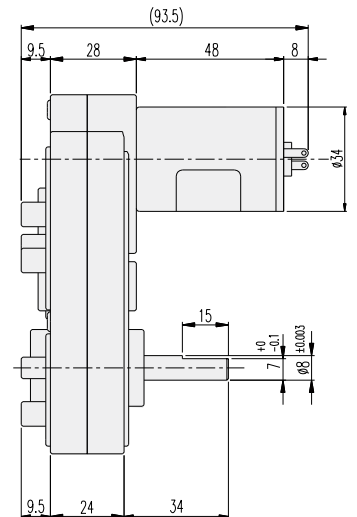

AT MAXIMUM EFFICIENCY

MODEL GEAR	KD3448S1		KD3448S2		KD3448T1		KD3448T2		KD3448P1		KD3448P2	
	rpm	kgf-cm	rpm	kgf-cm	rpm	kgf-cm	rpm	kgf-cm	rpm	kgf-cm	rpm	kgf-cm
1/0060	75	2.8	75	2.8	108.3	2.8	108.3	2.8	133.3	2.8	133.3	2.8
1/0070	64.2	3.2	64.2	3.2	92.8	3.2	92.8	3.2	114.2	3.2	114.2	3.2
1/0090	50	4	50	4	72.2	4	72.2	4	88.8	4	88.8	4
1/0105	42.8	4.8	42.8	4.8	62	4.8	62	4.8	76	4.8	76	4.8
1/0135	33.3	5.6	33.3	5.6	48	5.6	48	5.6	59.2	5.6	59.2	5.6
1/0200	22.5	8.4	22.5	8.4	32.5	8.4	32.5	8.4	40	8.4	40	8.4
1/0350	12.8	14.6	12.8	14.6	18.5	14.6	18.5	14.6	22.8	14.6	22.8	14.6
1/0500	9	20	9	20	13	20	13	20	16	20	16	20
1/0660	6.8	20	6.8	20	9.8	20	9.8	20	12	20	12	20

* 彩色齒輪比與電動機的旋轉方向相同。

KD□-34□□-TYPE

DIMENSIONS

KD3429□□ SERIES

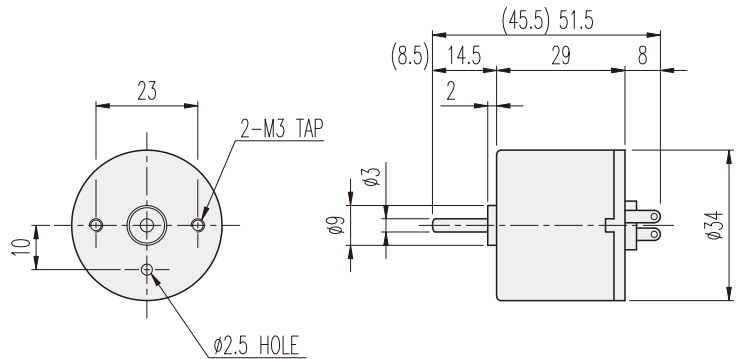

KD3448□□ SERIES

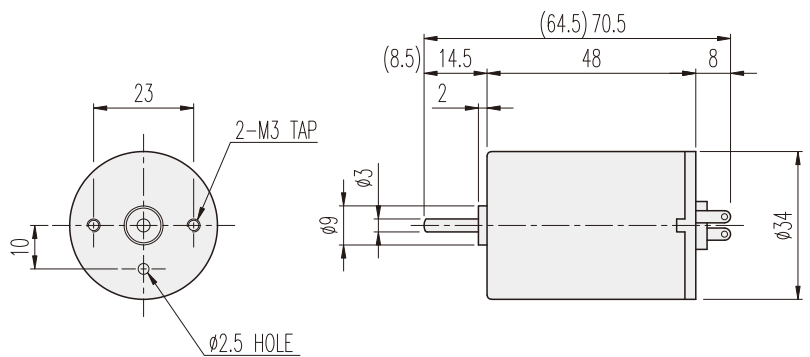

ENCODER SERIES

KD3429□□-E & 3448□□-E



6P-CONNECTOR 接线内容

No.1	連接內容	備註
1	DC MOOTR (+) 電源	供電時
2	DC MOOTR (-) 電源	MOTOR CCW - 逆轉
3	H/SENSOR (+) 電源	Vcc (+) DC 5 ~ 24V
4	H/SENSOR (-) 電源	GROUND
5	H/SENSOR #1 OUT	OPEN COLLECTOR MAX. DC 24V -50mA
6	H/SENSOR #1 OUT	

20極10脈衝 INCREMENTAL TYPE

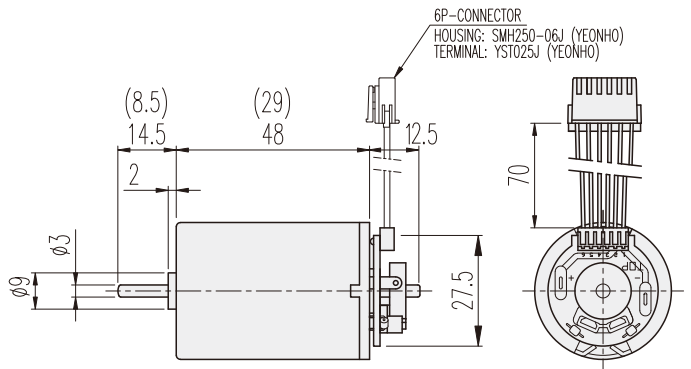

PERFORMANCE DATA

MODEL	ITEM	VOLTAGE (DC)	NO LOAD		AT MAX. EFF.		STALL		WEIGHT (g)
			mA	rpm	gf-cm	A	rpm	A	
90	KD3429S1	12V	120	5200	40	0.3	4500	1.7	360
	KD3429S2	24V	70	5200	40	0.2	4500	1	370
	KD3429T1	12V	150	7500	40	0.5	6500	3.8	420
	KD3429T2	24V	80	7500	40	0.2	6500	1.2	320
140	KD3429P1	12V	200	9500	80	1	8000	3.8	330
	KD3429P2	24V	100	9500	40	0.3	8000	2	350
	KD3448S1	12V	150	5200	80	0.5	4500	3.2	830
	KD3448S2	24V	80	5200	80	0.3	4500	2	790
	KD3448T1	12V	220	7500	80	0.7	6500	5	730
	KD3448T2	24V	100	7500	80	0.4	6500	3	700
	KD3448P1	12V	300	9000	80	0.8	8000	5.5	670
	KD3448P2	24V	200	9000	80	0.5	8000	3.5	750