

REVERSIBLE MOTOR

90W

□90mm

LEAD WIRE TYPE
TERMINAL BOX TYPE

K9RS90F□



K9RS90F□-T, T5



SPECIFICATIONS

90W 30分正格, 4极

Model		Voltage (V)	Frequency (Hz)	Current (A)	Start T. (N·m/kgf·cm)	Rated T. (N·m/kgf·cm)	Speed (rpm)	Condenser (μF)
K9R□90FJ(-T, -T5)	单 项	100	50	2,07	0,55/5,5	0,675/6,75	1300	30
			60	1,97		0,55/5,5	1600	
K9R□90FU(-T, -T5)	单 项	110	60	1,88	0,55/5,5	0,57/5,7	1550	25
		115		2,12				
K9R□90FL(-T, -T5)	单 项	200	50	0,9	0,55/5,5	0,705/7,05	1250	8
			60	1,1		0,57/5,7	1550	
K9R□90FC(-T, -T5)	单 项	220	50	1	0,5/5	0,705/7,05	1250	7
			60	1,1	0,53/5,3	0,57/5,7	1550	
		230	50	1,3	0,6/6	0,705/7,05	1250	
			60	1,1		0,57/5,7	1550	
K9R□90FD(-T, -T5)	单 项	240	50	0,94	0,55/5,5	0,705/7,05	1250	6

* □ : 电机轴形状 (S : STRAIGHT, P : PINION) * 型号名称末尾的 FU, FC 部件号是 UL 标准认证产品。UL FILE NO. E204632

RATED TORQUE OF GEARHEAD

● 50Hz

单位 = 上段 : N·m / 下段 : kgf·cm

Model	Speed(rpm)	500	416	300	250	200	166	150	120	100	83	75	60	50	41	37	30	25	20	16	15	12,5	10	8,3	7,5
Motor/ Gearhead	Ratio	3	3,6	5	6	7,5	9	10	12,5	15	18	20	25	30	36	40	50	60	75	90	100	120	150	180	200
K9R□90F□(-T, -T5) K9P□B, BF		1,71	2,06	2,86	3,43	4,28	5,14	5,71	6,42	7,71	9,25	10,28	11,56	13,88	16,65	18,5	20	20	20	20	20	20	20	20	20
		17,1	20,6	28,6	34,3	42,8	51,4	57,1	64,2	77,1	92,5	102,8	115,6	138,8	166,5	185,0	200	200	200	200	200	200	200	200	200

● 60Hz

单位 = 上段 : N·m / 下段 : kgf·cm

Model	Speed(rpm)	600	500	360	300	240	200	180	144	120	100	90	72	60	50	45	36	30	24	20	18	15	12	10	9
Motor/ Gearhead	Ratio	3	3,6	5	6	7,5	9	10	12,5	15	18	20	25	30	36	40	50	60	75	90	100	120	150	180	200
K9R□90F□(-T, -T5) K9P□B, BF		1,39	1,66	2,31	2,77	3,46	4,16	4,62	5,19	6,23	7,48	8,31	9,35	11,22	13,46	14,96	18,7	20	20	20	20	20	20	20	20
		13,9	16,6	23,1	27,7	34,6	41,6	46,2	51,9	62,3	74,8	83,1	93,5	112,2	134,6	149,6	187	200	200	200	200	200	200	200	200

* 减速机。中间减速机为另卖品

* 减速机品名中 □里 为减速比

* 色是与电机同一方向, 其它为反方向。

* 表 比此减速比还要高的减速比时可以使用中间减速机。此时的许容扭矩为20N·m/200kgfcm。

* 转速以电机同期转速 (50Hz : 1500RPM 60Hz : 1800RPM)为基准除以减速比计算出来的。实际转速根据负载的大小比表上的数据小2-20%。

GEARHEAD

RATED TORQUE OF GEARHEAD

● 50Hz

单位 = 上段: N·m / 下段: kgf·cm

Model	Speed(rpm)	500	416	300	250	200	166	150	120	100	83	75	60	50	41	37	30	25	20	16	15	13	10	8,3	7,5
Motor/ Gearhead	Ratio	3	3,6	5	6	7,5	9	10	12,5	15	18	20	25	30	36	40	50	60	75	90	100	120	150	180	200
K9R□90F□(-T, -T5) K9RP□BU, BUF		1,71	2,06	2,86	3,43	4,28	5,14	5,71	6,42	7,71	9,25	10,28	11,56	13,88	16,65	18,50	23,13	27,75	30	30	30	30	30	30	30
		17,1	20,6	28,6	34,3	42,8	51,4	57,1	64,2	77,1	92,5	102,8	115,6	138,8	165,6	185,0	231,3	277,5	300	300	300	300	300	300	300

● 60Hz

单位 = 上段: N·m / 下段: kgf·cm

Model	Speed(rpm)	600	500	360	300	240	200	180	144	120	100	90	72	60	50	45	36	30	24	20	18	15	12	10	9
Motor/ Gearhead	Ratio	3	3,6	5	6	7,5	9	10	12,5	15	18	20	25	30	36	40	50	60	75	90	100	120	150	180	200
K9R□90F□(-T, -T5) K9RP□BU, BUF		1,39	1,66	2,31	2,77	3,46	4,16	4,62	5,19	6,23	7,48	8,31	9,35	11,22	13,46	14,96	18,70	22,44	25,24	30	30	30	30	30	30
		13,9	16,6	23,1	27,7	34,6	41,6	46,2	51,9	62,3	74,8	83,1	93,5	112,2	134,6	149,6	187,0	224,4	252,4	300	300	300	300	300	300

* 减速机。中间减速机为另卖品

* 减速机品名中 □里 为减速比

* 色是与电机同一方向，其它为反方向。

* 表 比此减速比还要高的减速比时可以使用中间减速机。此时的许容扭矩为 30N·m / 300kgf·cm。

* 转速以电机同期转速 (50Hz: 1500RPM 60Hz: 1800RPM) 为基准除以减速比计算出来的。实际转速根据负载的大小比表上的数据小2-20%。

DIMENSIONS

K9RS90F□

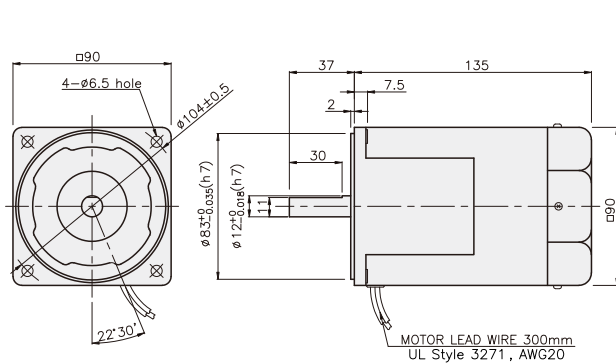

K9RS90F□-T

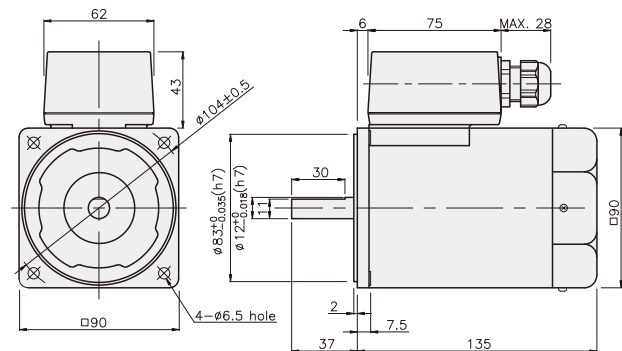

K9RS90F□-T5

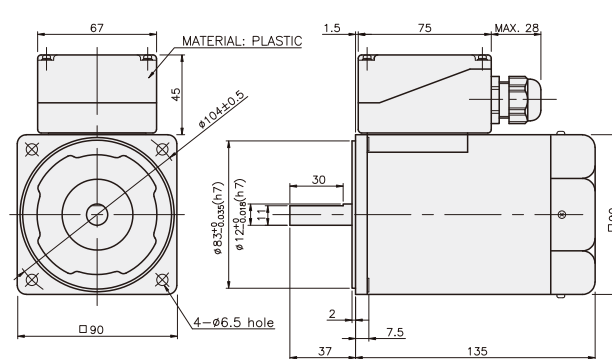

GEARHEAD

CONNECTION DIAGRAMS

K9RS90F□

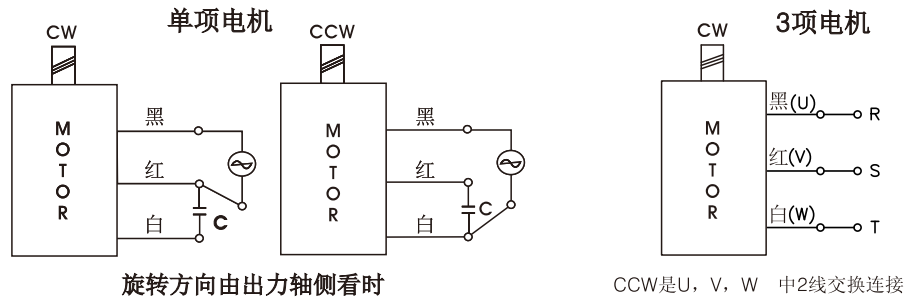

K9RS90F□-T

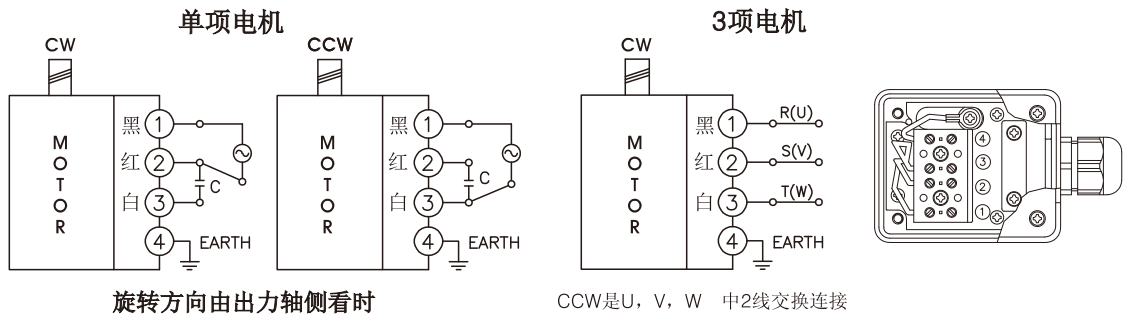

K9RS90F□-T5

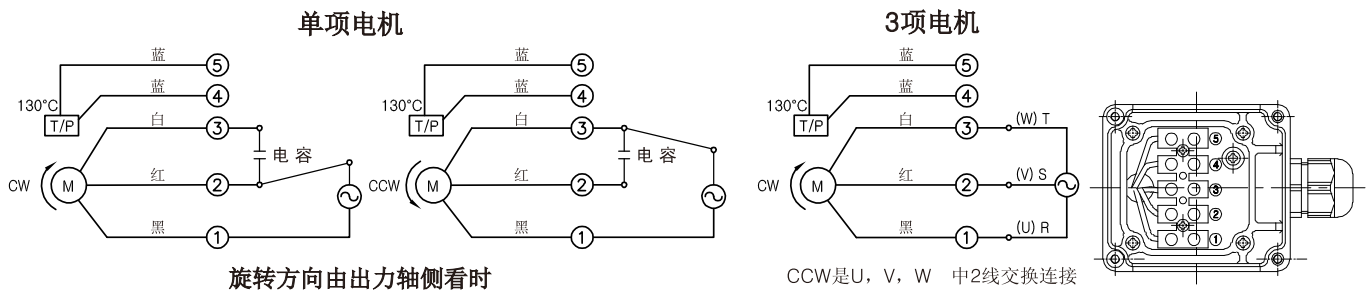

GEARHEAD

DIMENSIONS

K9P□B



K9P□BF, BUF



K9P□BU

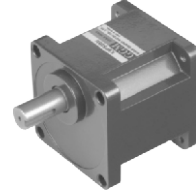

DECIMAL GEARHEAD

K9P10BX

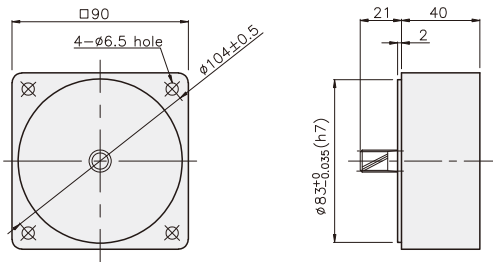

KEY SPEC

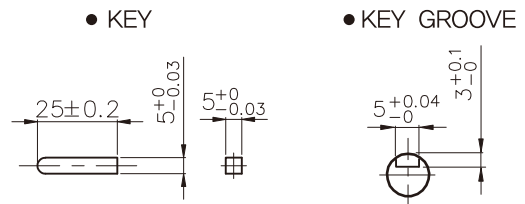

GEARHEAD

K9P□B

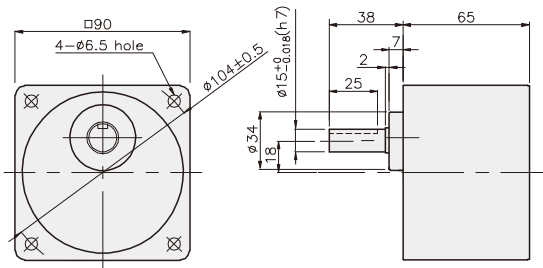

K9P□BF

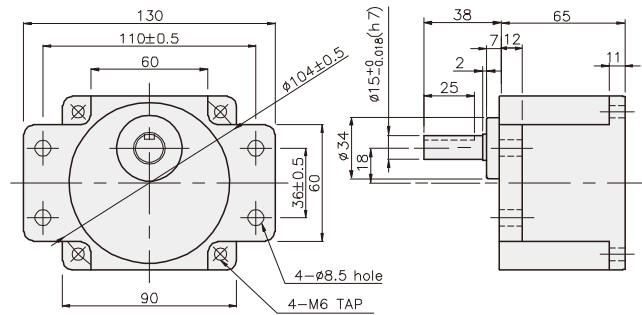

K9P□BU

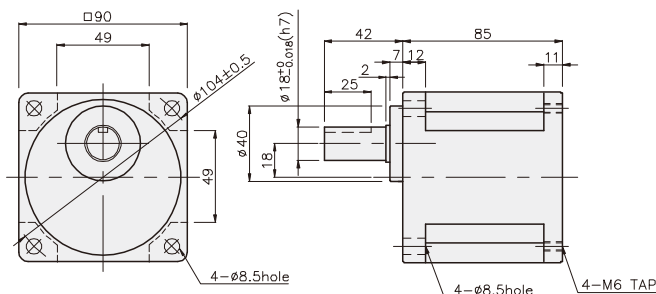

K9P□BUF

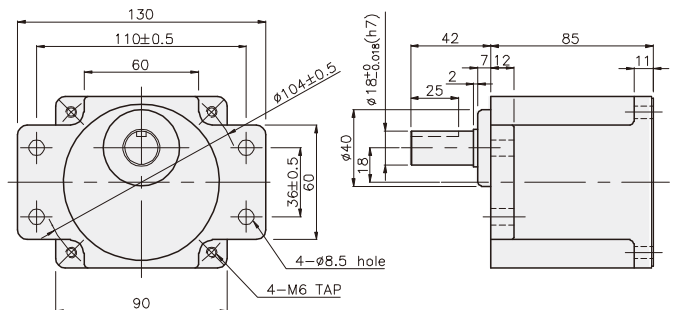

GEARHEAD

DIMENSIONS

K9RP90F□ + K9P□B



K9RP90F□ + K9P□BF, BUF



K9RP90F□ + K9P□BU

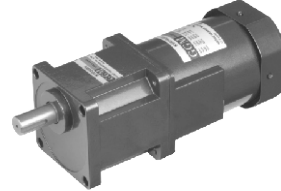

K9RP90F□ + K9P□B

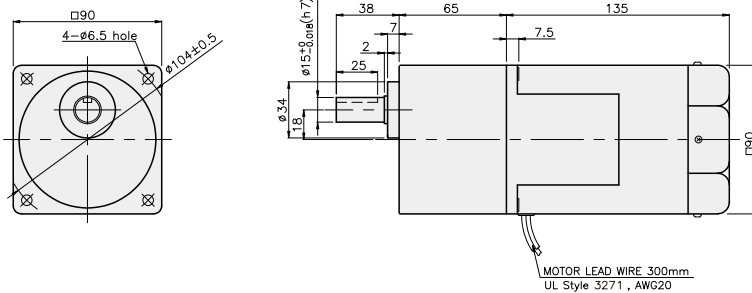

重量

PART	WEIGHT(kg)
MOTOR	3.00
DECIMAL GEAR HEAD	0.62

尺寸表

编号	应用型号	安装螺丝
01	K9P3~200B	M6 P1.0 X 95
02	K9P10BX	M6 P1.0 X 140

重量

PART	WEIGHT(kg)
K9P3~10B	1.22
K9P12.5~20B	1.32
K9P25~60B	1.42
K9P75~200B	1.45

尺寸表

编号	应用型号	安装螺丝
01	K9P3~200BF	M6 P1.0 X 20
02	K9P10BX	M6 P1.0 X 65

重量

PART	WEIGHT(kg)
K9P3~10BF	1.22
K9P12.5~20BF	1.30
K9P25~60BF	1.42
K9P75~200BF	1.44

K9RP90F□ + K9P□BF

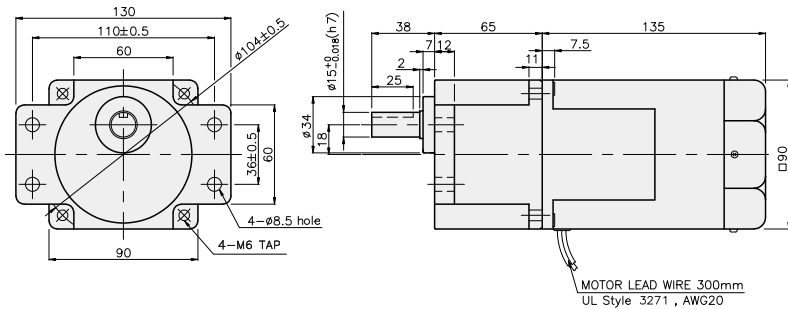

K9RP90F□ + K9P□BU

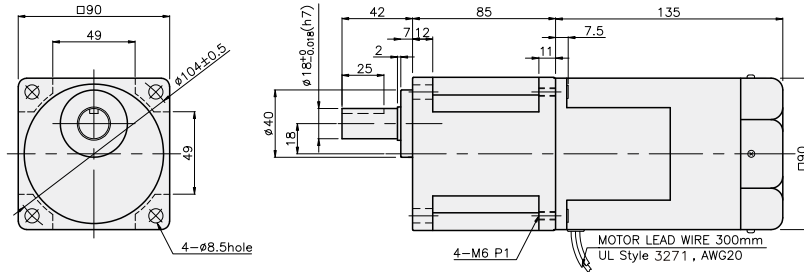

尺寸表

编号	应用型号	安装螺丝
01	K9P3~200BU	M6 P1.0 X 20
02	K9P10BX	M6 P1.0 X 65

重量

PART	WEIGHT(kg)
K9P3~10BU	1.44
K9P12.5~20BU	1.55
K9P25~60BU	1.69
K9P75~200BU	1.74

K9RP90F□ + K9P□BUF

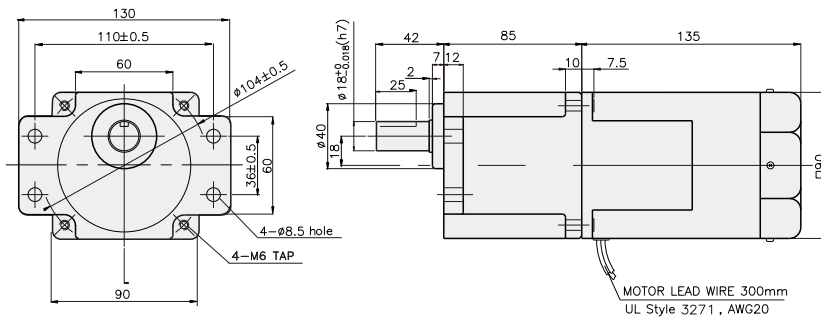

尺寸表

编号	应用型号	安装螺丝
01	K9P3~200BUF	M6 P1.0 X 20
02	K9P10BX	M6 P1.0 X 65

重量

PART	WEIGHT(kg)
K9P3~10BUF	1.50
K9P12.5~20BUF	1.62
K9P25~60BUF	1.76
K9P75~200BUF	1.82

GEARHEAD

DIMENSIONS

K9RP90F□-T + K9P□B



K9RP90F□-T + K9P□BF, BUF

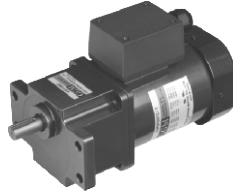

K9RP90F□-T + K9P□BU



重量

PART	WEIGHT(kg)
MOTOR	3.18
DECIMAL GEAR HEAD	0.62

尺寸表

编号	应用型号	安装螺丝
01	K9P3~200B	M6 P1.0 X 95
02	K9P10BX	M6 P1.0 X 140

重量

PART	WEIGHT(kg)
K9P3~10B	1.22
K9P12.5~20B	1.32
K9P25~60B	1.42
K9P75~200B	1.45

尺寸表

编号	应用型号	安装螺丝
01	K9P3~200BF	M6 P1.0 X 20
02	K9P10BX	M6 P1.0 X 65

重量

PART	WEIGHT(kg)
K9P3~10BF	1.22
K9P12.5~20BF	1.30
K9P25~60BF	1.42
K9P75~200BF	1.44

尺寸表

编号	应用型号	安装螺丝
01	K9P3~200BU	M6 P1.0 X 20
02	K9P10BX	M6 P1.0 X 65

重量

PART	WEIGHT(kg)
K9P3~10BU	1.44
K9P12.5~20BU	1.55
K9P25~60BU	1.69
K9P75~200BU	1.74

尺寸表

编号	应用型号	安装螺丝
01	K9P3~200BUF	M6 P1.0 X 20
02	K9P10BX	M6 P1.0 X 65

重量

PART	WEIGHT(kg)
K9P3~10BUF	1.50
K9P12.5~20BUF	1.62
K9P25~60BUF	1.76
K9P75~200BUF	1.82

K9RP90F□-T + K9P□B

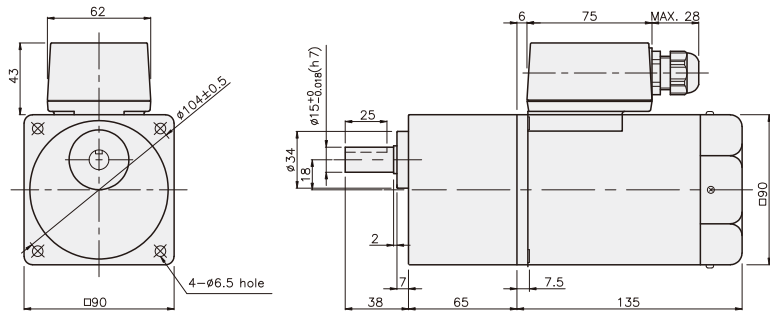

K9RP90F□-T + K9P□BF

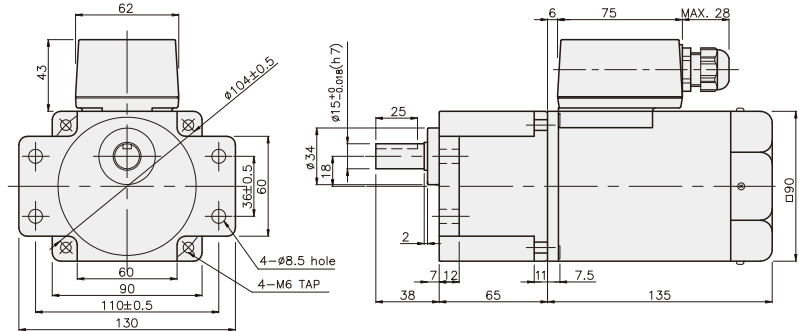

K9RP90F□-T + K9P□BU

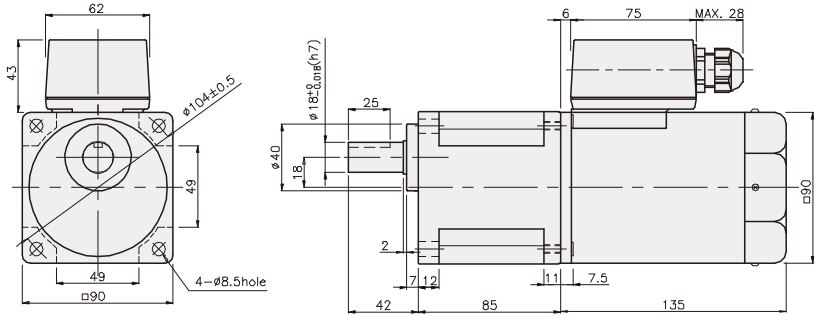

K9RP90F□-T + K9P□BUF

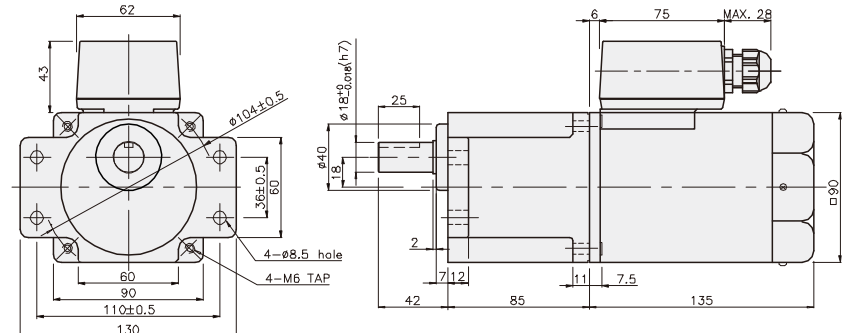

GEARHEAD

DIMENSIONS

K9RP90F□-T5 + K9P□B



K9RP90F□-T5 + K9P□BF, BUF

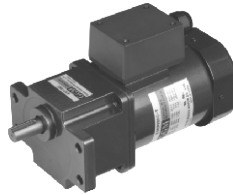

K9RP90F□-T5 + K9P□BU



K9RP90F□-T5 + K9P□B

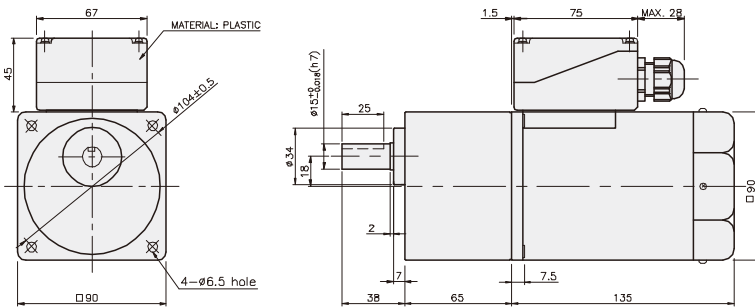

K9RP90F□-T5 + K9P□BF

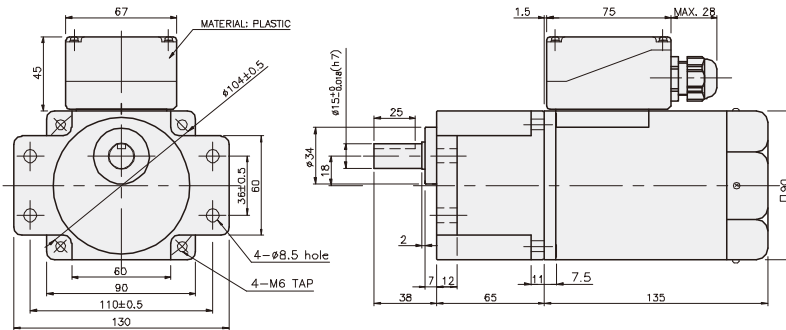

K9RP90F□-T5 + K9P□BU

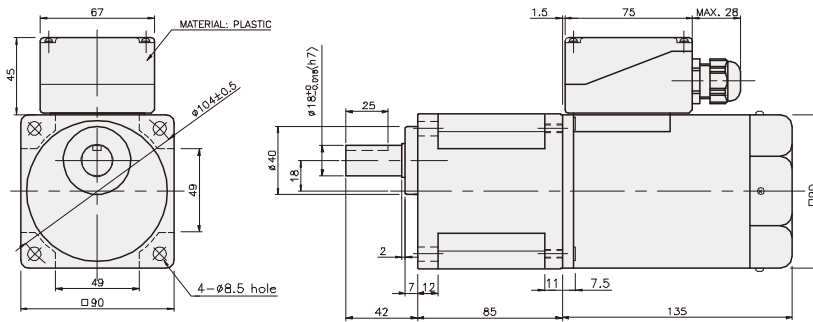

K9RP90F□-T5 + K9P□BUF

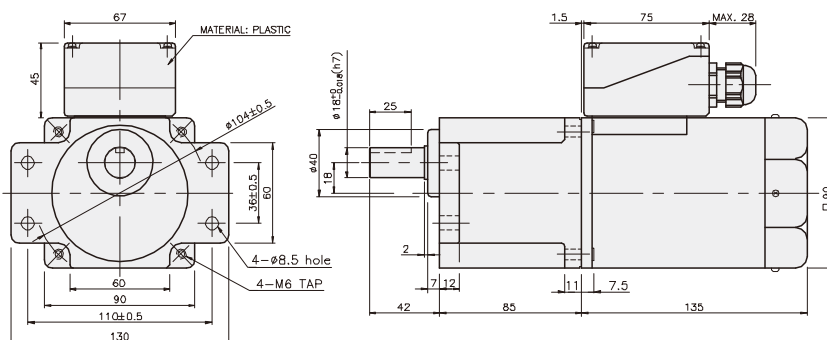

重量

PART	WEIGHT(kg)
MOTOR	3.18
DECIMAL GEAR HEAD	0.62

尺寸表

编号	应用型号	安装螺丝
01	K9P3~200B	M6 P1,0 X 95
02	K9P10BX	M6 P1,0 X 140

重量

PART	WEIGHT(kg)
K9P3~10B	1,22
K9P12,5~20B	1,32
K9P25~60B	1,42
K9P75~200B	1,45

尺寸表

编号	应用型号	安装螺丝
01	K9P3~200BF	M6 P1,0 X 20
02	K9P10BX	M6 P1,0 X 65

重量

PART	WEIGHT(kg)
K9P3~10BF	1,22
K9P12,5~20BF	1,30
K9P25~60BF	1,42
K9P75~200BF	1,44

尺寸表

编号	应用型号	安装螺丝
01	K9P3~200BU	M6 P1,0 X 20
02	K9P10BX	M6 P1,0 X 65

重量

PART	WEIGHT(kg)
K9P3~10BU	1,44
K9P12,5~20BU	1,55
K9P25~60BU	1,69
K9P75~200BU	1,74

尺寸表

编号	应用型号	安装螺丝
01	K9P3~200BUF	M6 P1,0 X 20
02	K9P10BX	M6 P1,0 X 65

重量

PART	WEIGHT(kg)
K9P3~10BUF	1,50
K9P12,5~20BUF	1,62
K9P25~60BUF	1,76
K9P75~200BUF	1,82