

## DC MOTOR

25W ~ 40W

□80mm

### DIMENSIONS

K8DS□N□

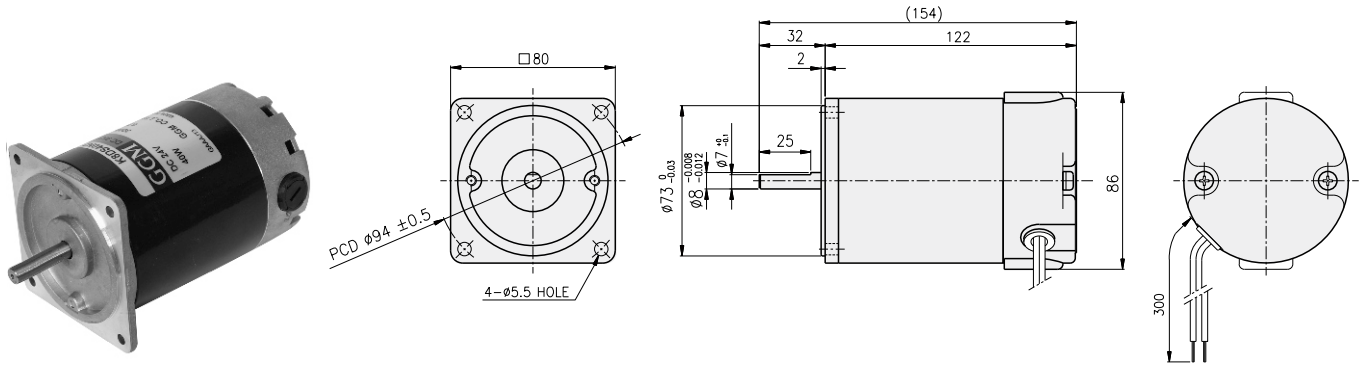

### CONNECTION DIAGRAMS

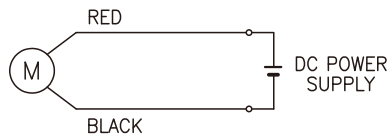

當向紅線施加+電源時，順時針旋轉 (CW)。  
 當向黑線施加+電源時，逆時針旋轉 (CCW)。  
 ※ 從輸出軸的正面看時，這就是旋轉方向。

### SPECIFICATIONS

Model	Output (W)	Voltage (V)	RATED			Start T. (N·m/kgf·cm)	Starting Current (A)
			Speed (rpm)	Torque (N·m/kgf·cm)	Current (A)		
K8D□25N1	25	12	3000	0.08/0.8	5	1.2/12	55
K8D□25N2		24			2.3	1.3/13	28
K8D□25N3		90			0.6	0.8/8	5
K8D□40N1	40	12		0.13/1.3	6.1	1.43/14.3	64
K8D□40N2		24			3	1.82/18.2	40
K8D□40N3		90			0.9	1.44/14.4	9

\* □ : 电机轴形状 (S : STRAIGHT, G : PINION)

## GEARHEAD

### DIMENSIONS

DECIMAL GEARHEAD  
K8G10BX

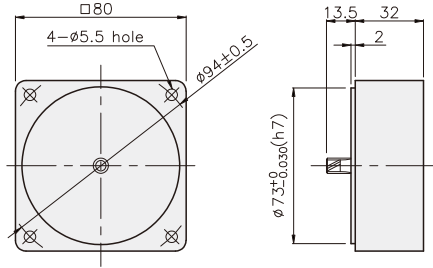

GEARHEAD  
K8G□B(C)

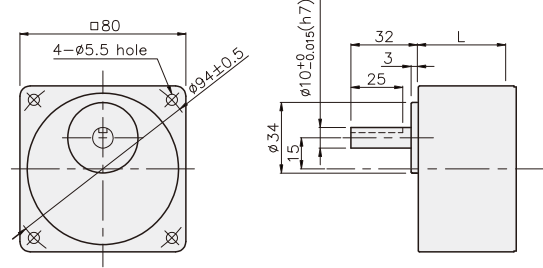

#### KEY SPEC

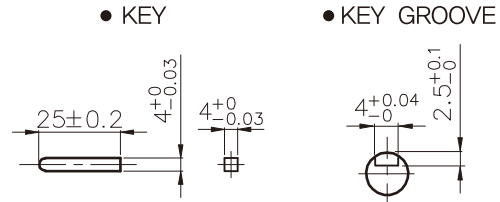

#### 尺寸表 / 應用BOLT

编号	L	应用型号	安装螺丝
01	32	K8G3~18B(C)	M5 P0.8 × 50
02	42.5	K8G20~250B(C)	M5 P0.8 × 65
03	32	K8G10BX	M5 P0.8 X 95

#### 重量

PART	WEIGHT(kg)	
MOTOR	1.76	
K8G10BX	0.46	
GEAR HEAD	K8G3~18B(C)	0.51
	K8G20~40B(C)	0.64
	K8G50~250B(C)	0.70

K8DG□N□ + K8G□B(C)

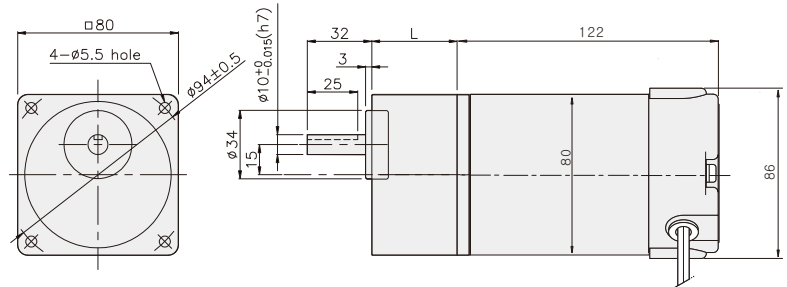

### RATED TORQUE OF GEARHEAD

#### ● K8G□B(C)

单位 = 上段: N·m / 下段: kgf·cm

Model Motor/ Gearhead	Speed(rpm) Ratio	1000	833	600	500	400	333	300	240	200	167	150	120	100	83	75	60	50	40	33	30	25	20	17	15	12
		3	3.6	5	6	7.5	9	10	12.5	15	18	20	25	30	36	40	50	60	75	90	100	120	150	180	200	250
K8DG25N□	0.20	0.24	0.33	0.39	0.49	0.59	0.66	0.82	0.99	1.18	1.18	1.48	1.77	2.13	2.36	2.66	3.19	3.99	4.79	5.32	6.39	7.98	8	8	8	
	2.0	2.4	3.3	3.9	4.9	5.9	6.6	8.2	9.9	11.8	11.8	14.8	17.7	21.3	23.6	26.6	31.9	39.9	47.9	53.2	63.9	79.8	80	80	80	
K8DG40N□	0.32	0.38	0.53	0.63	0.79	0.95	1.05	1.31	1.58	1.89	1.89	2.37	2.84	3.41	3.78	4.26	5.11	6.39	7.66	8	8	8	8	8	8	
	3.2	3.8	5.3	6.3	7.9	9.5	10.5	13.1	15.8	18.9	18.9	23.7	28.4	34.1	37.8	42.6	51.1	63.9	76.6	80	80	80	80	80	80	

\* 减速机。中间减速机为另卖品

\* 减速机品名中 □ 里 为减速比

\* 色是与电机同一方向，其它为反方向。

\* 表 比此减速比还要高的减速比时可以使用中间减速机。此时的许容扭矩为 8N·m/80kgf·cm。