

GEARHEAD

DIMENSIONS

K10IS200F□

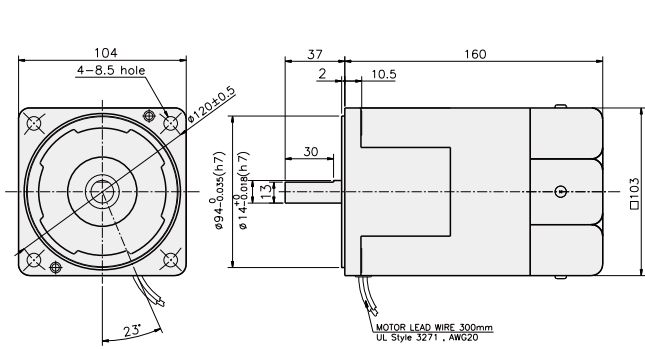

K10IS200F□-T

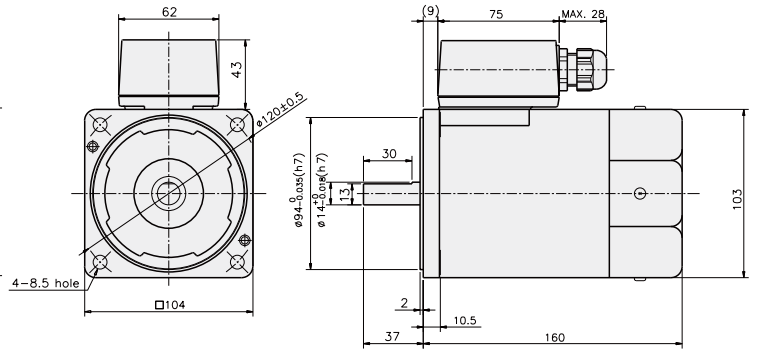

K10IS200F□-T5

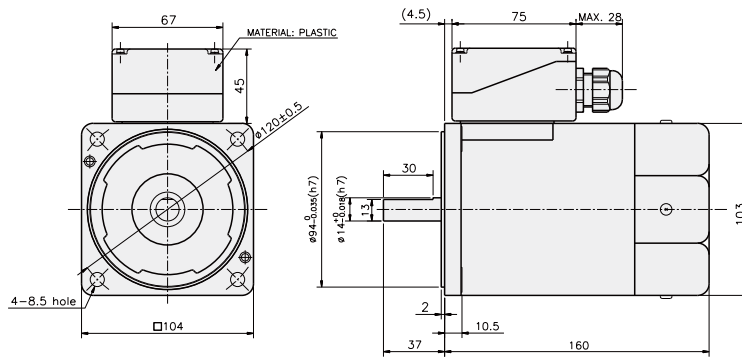

CONNECTION DIAGRAMS

K10IS200F□

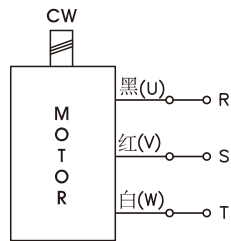

旋转方向由出力轴侧看时

K10IS200F□-T

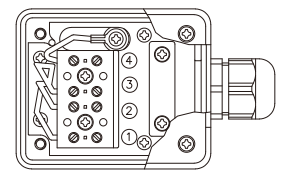
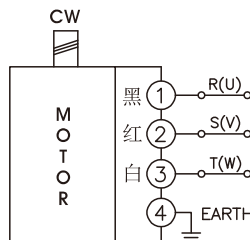

旋转方向由出力轴侧看时

K10IS200F□-T5

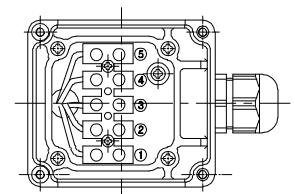
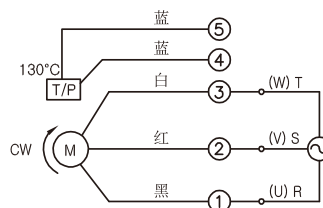

旋转方向由出力轴侧看时

GEARHEAD

DIMENSIONS

K10H□B

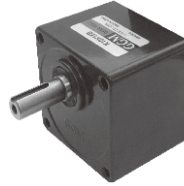

GEARHEAD

K10H□B

KEY SPEC

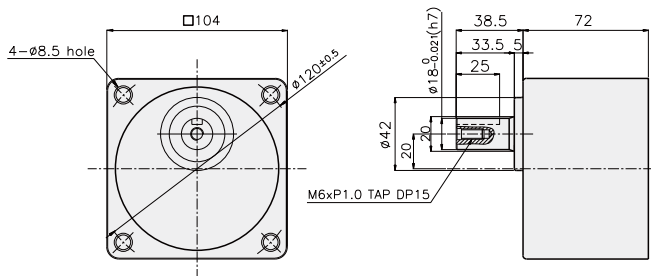

● KEY

● KEY GROOVE

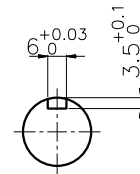
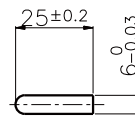

GEARHEAD

DIMENSIONS

K10IH200F□ + K10H□B

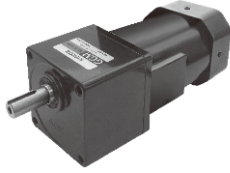

K10IH200F□-T + K10H□B

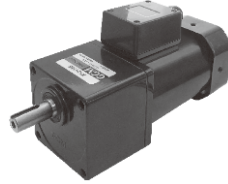

K10IH200F□-T5 + K10H□B

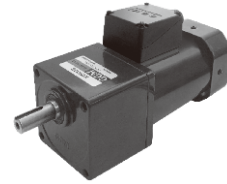

K10IH200F□ + K10H□B

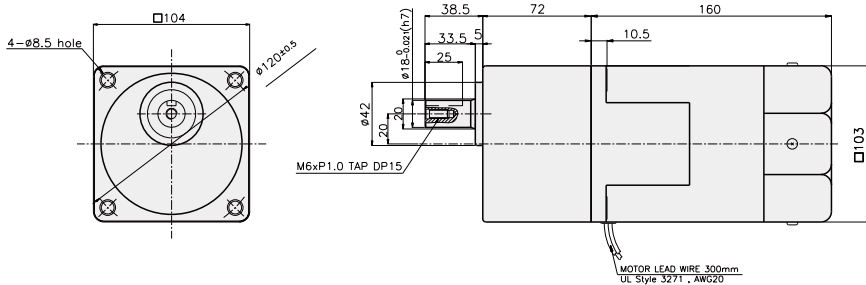

重量

PART		WEIGHT(kg)
MOTOR		4,70
GEAR HEAD	K10H3~10B	1,80
	K10H12,5~40B	2,00
	K10H50~200B	2,20

尺寸表

编号	应用型号	安装螺丝
01	K10H3~200B	M8 P1,25 X 100

K10IH200F□-T + K10H□B

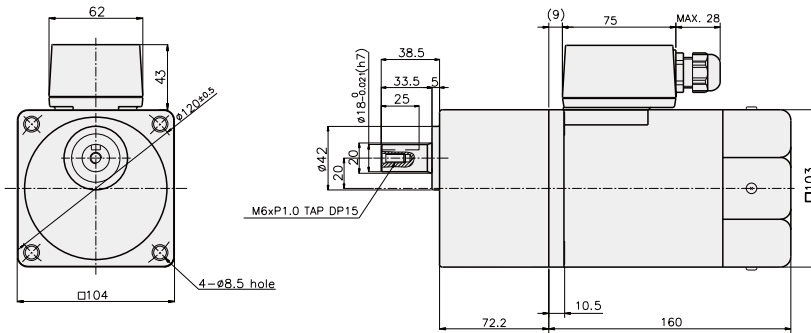

重量

PART		WEIGHT(kg)
MOTOR		4,88
GEAR HEAD	K10H3~10B	1,80
	K10H12,5~40B	2,00
	K10H50~200B	2,20

尺寸表

编号	应用型号	安装螺丝
01	K10H3~200B	M8 P1,25 X 100

K10IH200F□-T5 + K10H□B

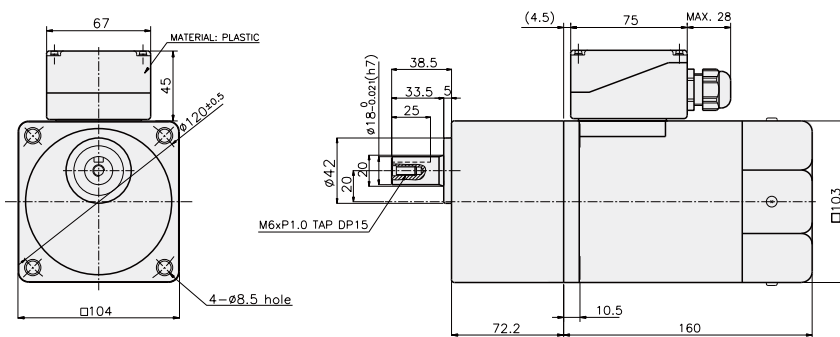

重量

PART		WEIGHT(kg)
MOTOR		4,88
GEAR HEAD	K10H3~10B	1,80
	K10H12,5~40B	2,00
	K10H50~200B	2,20

尺寸表

编号	应用型号	安装螺丝
01	K10H3~200B	M8 P1,25 X 100